

**HotSpring**<sup>®</sup>  
*Portable Spas*

**OWNER'S  
MANUAL**

**Watkins  
Manufacturing  
Corporation**



**HotSpring**<sup>®</sup>  
*Portable Spas*

# OWNER'S MANUAL

The Serial Number/Identification label is located within the equipment compartment of your HOT SPRING SPA.

**IMPORTANT:** Watkins Manufacturing Corporation reserves the right to change specifications or design without notification and without incurring any obligation.

L'étiquette d'identification indiquant le numéro de série est située à l'intérieur du compartiment d'équipement de votre Hot Spring Spa.

**IMPORTANT:** Watkins Manufacturing Corporation se réserve le droit de modifier les caractéristiques ou le design sans notification et sans encourir d'obligation.

DATE PURCHASED:

DATE D'ACHAT

DATE INSTALLED:

DATE D'INSTALLATION

DEALER:

DETAILLANT

ADDRESS:

ADRESSE

TELEPHONE:

TELEPHONE

SPA MODEL/SERIAL NUMBER:

MODELE DU SPA/NUMERO DE SERIE

**WELCOME TO  
THE WONDERFUL  
WORLD OF HOT SPRING SPA.**

■ This Owner's Manual has been expressly designed to acquaint you with your new spa's operation and general maintenance. We suggest that you take some time to carefully review all seven sections in this manual. Please keep this manual available for reference.

■ If you have questions about any aspect of your HOT SPRING SPA's set-up, operation or maintenance, Watkins Manufacturing Corporation's Customer Service Department can be reached toll-free at:

**WATKINS MANUFACTURING CORPORATION**

1280 Park Center Drive, Vista, CA 92083  
(800) 999-4688, (Extension 432)

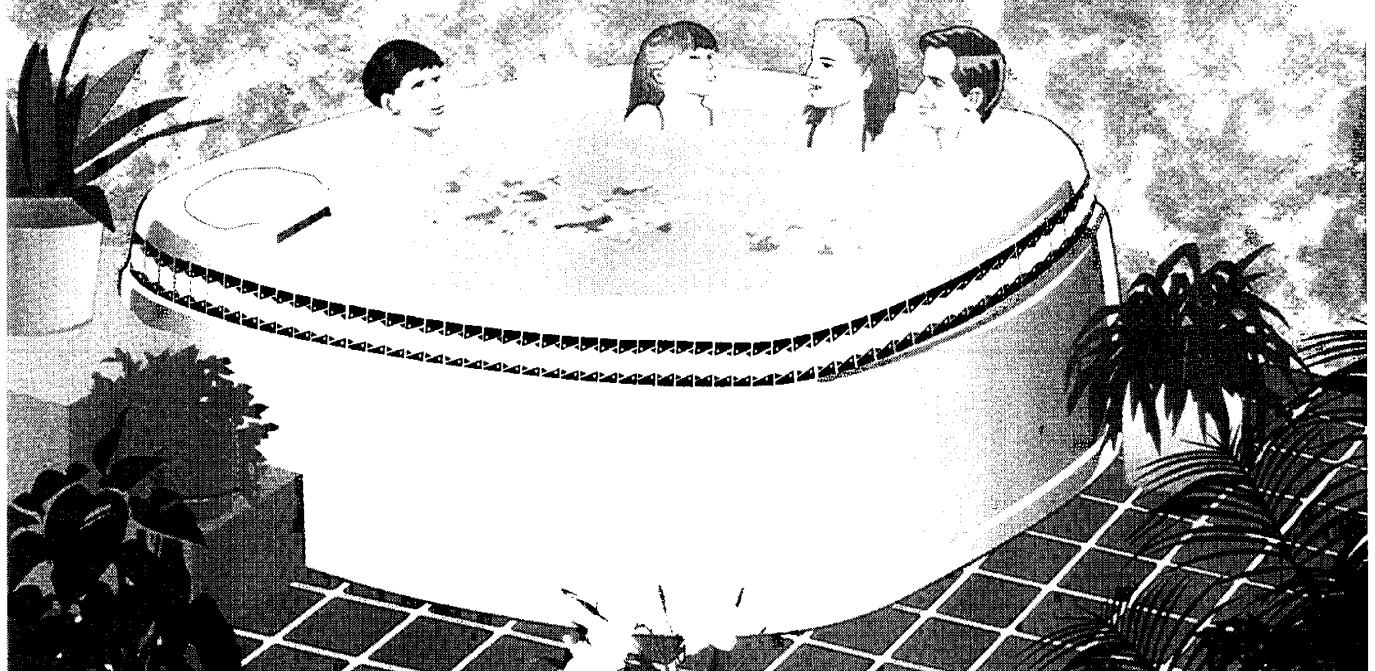

The following instructions are required to be printed by Underwriters Laboratories as a condition of their listing of this product. They contain important safety information, and we strongly encourage you to read and apply them.

## **IMPORTANT SAFETY INSTRUCTIONS**

When installing and using this electrical equipment, basic safety precautions should always be followed, including the following:

1. **READ AND FOLLOW ALL INSTRUCTIONS**
2. **DANGER**—To reduce the risk of injury, do not permit children to use this unless they are closely supervised at all times.
- 2A. **WARNING—RISK OF CHILD DROWNING.** Extreme caution must be exercised to prevent unauthorized access by children. To avoid accidents, ensure that children cannot use the spa unless they are supervised at all times.

### **110 Volt, cord and plug connected – Models F, H, IJ**

3. Connect only to a grounded, grounding type receptacle.
4. Do not bury the power cord.
5. **WARNING**—To reduce the risk of electric shock, replace a damaged cord immediately.
6. A ground terminal (pressure wire connector) is provided on the surface of the control box inside the equipment compartment. To reduce the risk of electric shock, this connector should be bonded with a minimum No. 8 AWG (8.4mm<sup>2</sup>) solid copper wire to any metal ladders, water pipes, or other metal enclosures or

equipment within 5 feet (1.52m) of the spa to comply with local requirements.

7. Your spa is equipped with a ground fault circuit interrupter (G.F.C.I.) on the end of the power supply cord. Before each use of the spa, with the plug connected to the power supply and the unit operating, push the “Test” button. The unit should stop operating and the “Reset” button should appear. Reset the G.F.C.I. by pushing the “Reset” button. The spa should now operate normally. If the interrupter does not perform in this manner, a ground current is flowing indicating the possibility of an electric shock. Disconnect the plug from the receptacle until the fault has been identified and corrected.

### **220 Volt, permanently installed models with G.F.C.I.—Models G, K, FH, IH**

8. A green colored terminal marked “G” is provided in the wiring box located inside the equipment compartment. To reduce the risk of electric shock, connect this terminal or connector to the grounding terminal of your electric service or supply panel with a continuous green, insulated copper wire. This wire must be equivalent in size to the circuit conductors supplying the equipment. In addition, a second wire connector is provided for bonding to local ground points. To reduce the risk of electric shock, this connector should be bonded with a No. 8 AWG (8.4mm<sup>2</sup>) solid copper wire to any metal ladders, water pipes, or other metal within 5 feet (1.52m) of the spa to comply with local requirements.
9. Your spa comes with ground fault circuit interrupter breakers in the sub-panel provided with the unit. Before each use of the spa and with the unit operating, push the “Test” button on each breaker. The switch should click over to the “Trip” position. Reset each G.F.C.I. breaker by

switching it completely off and then completely on. The switch should then stay on. If any of the interrupters do not perform in this manner, a ground current is flowing indicating the possibility of an electric shock. Disconnect the power until the fault has been identified and corrected.

10. Install the spa so proper drainage is provided for the compartment containing the electrical components.
11. DANGER—RISK OF ELECTRIC SHOCK. Install the spa at least 5 feet (1.5m) from all metal surfaces. (A spa may be installed within 5 feet of metal surfaces if, in accordance with the National Electrical Code ANSI/NMFA70-1984, each metal surface is permanently connected by a No. 8 AWG (8.4mm<sup>2</sup>) solid copper conductor attached to the wire connector on the terminal box that is provided for this purpose.)
12. DANGER—RISK OF ELECTRIC SHOCK. Do not permit any electric appliance, such as a light, telephone, radio, or television, within 5 feet (1.5m) of the spa.
13. To reduce the risk of injury:
  - The water in the spa should never exceed 40 deg. C (104 degrees F). Water temperatures between 38 deg. C (100 degrees F) and 40 deg. C (104 degrees F) are considered safe for a healthy adult. Lower water temperatures are recommended for extended use (exceeding 10-15 minutes) and for young children.
  - Since excessive water temperatures have a high potential for causing fetal damage during the early months of pregnancy, pregnant or possibly pregnant women should limit spa water temperatures to 38 deg. C (100 degrees F).
  - Before entering a spa, the user should measure the water temperature with

an accurate thermometer since the tolerance of water temperature-regulating devices may vary as much as +/- 3 deg. C (5 degrees F).

- The use of alcohol, drugs, or medication before or during spa use may lead to unconsciousness with the possibility of drowning.
- Persons suffering from obesity or with a medical history of heart disease, low or high blood pressure, circulatory system problems or diabetes should consult a physician before using a spa.
- Persons using medications should consult a physician before using a spa since some medication may induce drowsiness while other medication may affect heart rate, blood pressure, or circulation.

14. **SAVE THESE INSTRUCTIONS.**

# TABLE OF CONTENTS

---

## I. GENERAL INFORMATION

Personal Safety .....	5
-----------------------	---

---

## II. INSTALLATION INSTRUCTIONS

Site Preparation/Positioning Your Spa .....	6
Electrical Requirements 220 Volt Models .....	6
Electrical Requirements 110 Volt Models .....	9

---

## III. SPA SPECIFICATIONS

Features of your HOT SPRING SPA .....	12
GRANDEE (Model G) .....	13
HIGHLIFE (Model K) .....	14
CLASSIC (Model F) .....	15
SOVEREIGN (Model I) .....	16
CLASSIC (Model FH) .....	17
SOVEREIGN (Model IH) .....	17
PRODIGY (Model H) .....	18
JETSETTER (Model J) .....	19

---

## IV. OPERATING INSTRUCTIONS

General Information .....	20
Start-up Procedures .....	21
Hydrotherapy Jet System .....	22
MOTO-MASSAGE JET .....	23
JETSTREAM .....	24
Stationary Jets .....	24
Control Panel .....	24
Light .....	25

---

## V. SPA CARE AND MAINTENANCE

General Information .....	26
Draining the Water .....	26

Filter Maintenance .....	26
Filter Cartridge .....	27
Care of the Exterior Finish .....	28
Care of the Thermal Cover .....	28
Prevention of Freezing .....	30
Winterizing .....	30

---

## VI. WATER QUALITY AND MAINTENANCE

General Information .....	32
Water Chemistry Terminology ....	33
Use of the Test Kit .....	34
Adding Spa Water Chemicals ....	35
Sanitation .....	36
Water Purification—Ozone .....	37
pH Control .....	38
Supplemental Water Maintenance .....	38
Spa Water Maintenance — Troubleshooting Guide .....	39
Chemical Safety and Storage .....	40
Do's and Don'ts of Spa Water Maintenance .....	40

---

## VII. SERVICE INFORMATION

General Information .....	41
G.F.C.I. and High Limit Thermostats .....	41
Ozone Purification System .....	41
Miscellaneous Service Information .....	42
Acts Invalidating Warranty .....	42
Disclaimers .....	42

## I. GENERAL INFORMATION

### PERSONAL SAFETY

Prolonged immersion in water that is warmer than normal body temperature can result in a dangerous condition known as HYPERTHERMIA. The causes, symptoms, and effects of hyperthermia may be described as follows: Hyperthermia occurs when the internal temperature of the body reaches a level several degrees above the normal body temperature of 98.6 degrees F. The symptoms of hyperthermia include dizziness, fainting, drowsiness, lethargy, and an increase in the internal temperature of the body. The effects of hyperthermia include (1) unawareness of impending hazard, (2) failure to perceive heat, (3) failure to recognize the need to exit the spa, (4)

physical inability to exit the spa, (5) fetal damage in pregnant women, and (6) unconsciousness resulting in a danger of drowning. **WARNING**—The use of alcohol, drugs, or medication can greatly increase the risk of fatal hyperthermia in hot tubs and spas.

Persons taking medications which induce drowsiness such as tranquilizers, anti-histamines or anti-coagulants should not use the spa. Pregnant women and persons with a medical history of heart disease, circulatory problems, diabetes or high blood pressure should consult their physician before using the spa.

Children are especially sensitive to hot water. At no time should children have unsupervised access to the spa. The use of elevated decking may encourage children to climb onto the thermal cover—**IT IS NOT DESIGNED AS A SAFETY COVER!** The HOT SPRING SPA has child resistant locks for use with the thermal cover—lock them for your children's safety.

## DO's AND DON'Ts

- |           |   |                 |   |
|-----------|---|-----------------|---|
| <b>DO</b> | be sure your spa is connected to the power supply correctly - use a licensed electrical contractor.               |                 |   |
| <b>DO</b> | disconnect the spa from the power supply before draining the spa or servicing the electrical components.          | <b>DON'T</b>    | may affect the performance of the hydrotherapy jets.  |
| <b>DO</b> | test the Ground Fault Circuit Interrupter(s) monthly.   | <b>DON'T</b>    | use the spa for long periods of time at water temperatures in excess of 104 degrees F.  |
| <b>DO</b> | test the water temperature with your hand before entering the spa to be sure that it's comfortable.               | <b>DON'T</b>    | connect your spa to an extension cord (110 volt cord and plug connected models).  |
| <b>DO</b> | remember that wet surfaces can be very slippery. Take care when entering and exiting the spa.                     | <b>DON'T</b>    | allow the hydrotherapy jet pump to operate for extended periods of time with the thermal cover in place. Extended pump operation will cause a slow heat build-up due to water friction and will trip the spa's high limit thermostat.   |
| <b>DO</b> | use the thermal cover when the spa is not in use, empty or full.  | <b>DON'T</b>    | operate the spa at any time with the filter cartridge removed.  |
| <b>DO</b> | keep the water clean, clear and sanitized by correct chemical care.   | <b>DON'T</b>    | lift or drag the vinyl thermal cover by using the tie-down straps; always lift or carry the cover by using the handles.   |
| <b>DO</b> | add all spa water chemicals directly into the filter compartment while the hydrotherapy pump(s) is/are operating. | <b>DON'T</b>    | hesitate to call your HOT SPRING SPA representative with any questions or maintenance problems.   |
| <b>DO</b> | follow the Spa Care and Maintenance recommendations stated in this manual.  | <b>WARNING:</b> | Watkins Manufacturing Corporation recommends that the HOT SPRING SPA be installed above ground. Lowering the top of the spa to ground level, or employing decking which raises standing level toward the top of the spa substantially increases the hazard of accidental entry. |
| <b>DO</b> | clean the filter cartridge(s) monthly to remove debris and mineral buildup which                                  |                 |   |

## **II. INSTALLATION INSTRUCTIONS**

### **SITE PREPARATION / POSITIONING YOUR SPA**

Your HOT SPRING SPA is totally self-contained and portable. You can locate it just about anywhere you wish—on a patio, deck, or even indoors. Regardless of your choice, the spa should always be placed on a structurally strong, level surface. Once in place, the spa will need to be leveled (refer to enclosed Spa Leveling Instructions). When selecting an installation site, be sure to allow for drainage away from the equipment compartment which houses the electrical components. The installation site should allow for easy access to the Ground Fault Circuit Interrupter (G.F.C.I.) breakers which are located in the sub-panel on 220 volt spa models, or the 110 volt G.F.C.I. switch which is located on the end of the power cord on 110 volt spa models for monthly testing. The 110 volt G.F.C.I. switch and the receptacle it is plugged into must be protected from weather and landscape sprinklers—they should never get wet. The 220 volt G.F.C.I. sub-panel is a “Raintight” rated enclosure when installed correctly and the panel door is closed securely. Allowing moisture to enter either the sub-panel or receptacle will result in tripping of the main circuit breaker in the house electric panel. Allow for access to the equipment compartment for periodic spa care and maintenance.

### **Outdoor/Patio Installation**

If you install the spa outdoors, we recommend that you provide a 3"-4" thick concrete pad. Should it be necessary to temporarily place the spa on a soft surface (grass, dirt, etc.) 2"x12"x12" stepping stones should be placed at the designated leveling areas (see enclosed Spa Leveling Instructions). It is important to note that soft foundations, even when stepping stones are used to evenly distribute the weight of the spa, will still have a tendency to settle thus resulting in an unlevel spa. Also, placing the spa on grass or dirt may increase the amount of debris which is inadvertently brought into the spa water on users' feet.

Your HOT SPRING SPA dealer may offer a variety of Specialty Wood Products and enclosures. These include free-standing gazebos, skirt mounted gazebos, spa enclosures, spa settings and decks. Should you have your spa installed with any of these accessory items, a solid foundation is mandatory to ensure stability of the structure or deck.

### **Deck Installation**

Please refer to the Spa Specification Section of this manual for the dead weight per square foot. These figures do not take into consideration occupant weight. Should you be unsure of your deck's maximum load capacity, please consult a qualified building contractor or structural engineer.

### **Indoor Installation**

Water which splashes on the floor during use of the spa may cause a walking hazard and/or structural damage to the dwelling unless good drainage is provided. Proper building materials must be used in the area surrounding and beneath the spa. Take into consideration the room humidity which will exist due to high spa water temperatures. Providing natural or forced ventilation into the room will help maintain comfort and minimize moisture damage to the building. Consult an architect for aid in designing your indoor spa or garden room.

**NOTE:** Your HOT SPRING SPA dealer can answer many of your questions regarding local zoning requirements and building codes. In addition, the following planning aids are available from your dealer:

- HOT SPRING SPA - Pre-Delivery Instructions
- HOT SPRING SPA - Backyard Planning Guide
- SUNSET BOOKS - Spas, Hot Tubs, and Home Saunas

### **ELECTRICAL REQUIREMENTS AND PRECAUTIONS GENERAL INFORMATION**

Your HOT SPRING SPA has been carefully engineered to provide maximum safety against electric shock. Remember, connecting the spa to an improperly wired circuit will negate many of its safety features. Please read and follow the electrical installation requirements and instructions for your specific spa model completely!

### **220 VOLT MODELS GRANDEE (Model G) HIGHLIFE (Model K) CLASSIC (Model FH) SOVEREIGN (Model IH)**

#### **Electrical Requirements**

HOT SPRING SPAS MUST BE WIRED IN ACCORDANCE WITH ALL APPLICABLE, LOCAL ELECTRICAL CODES. ALL ELECTRICAL WORK SHOULD BE DONE BY AN EXPERIENCED, LICENSED ELECTRICIAN. WE RECOMMEND THE USE OF APPROPRIATE ELECTRICAL CONDUIT, FITTINGS, AND WIRE FOR ALL CIRCUITS.

An electrical sub-panel containing 2 G.F.C.I. breakers is included with the spa. WE RECOMMEND THAT THIS SUB-PANEL BE USED TO SUPPLY POWER AND PROTECT THE SPA.



### GRANDEE (Model G) and HIGHLIFE (Model K)

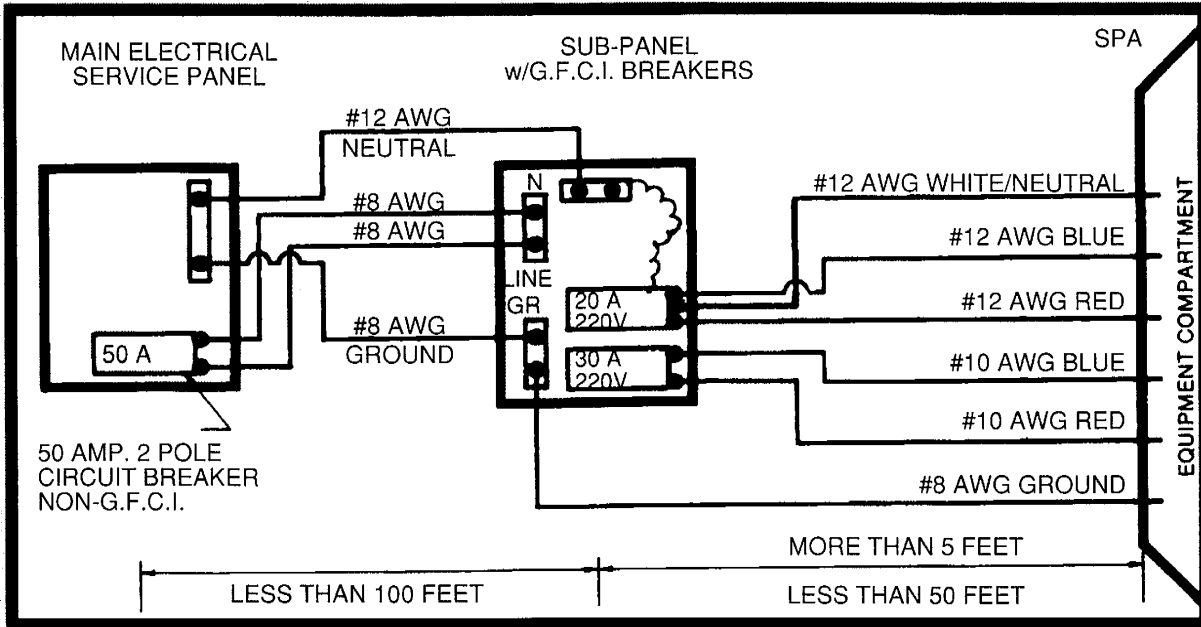

NOTE: ALL WIRING SHOULD BE COPPER

### CLASSIC (Model FH) and SOVEREIGN (Model IH)

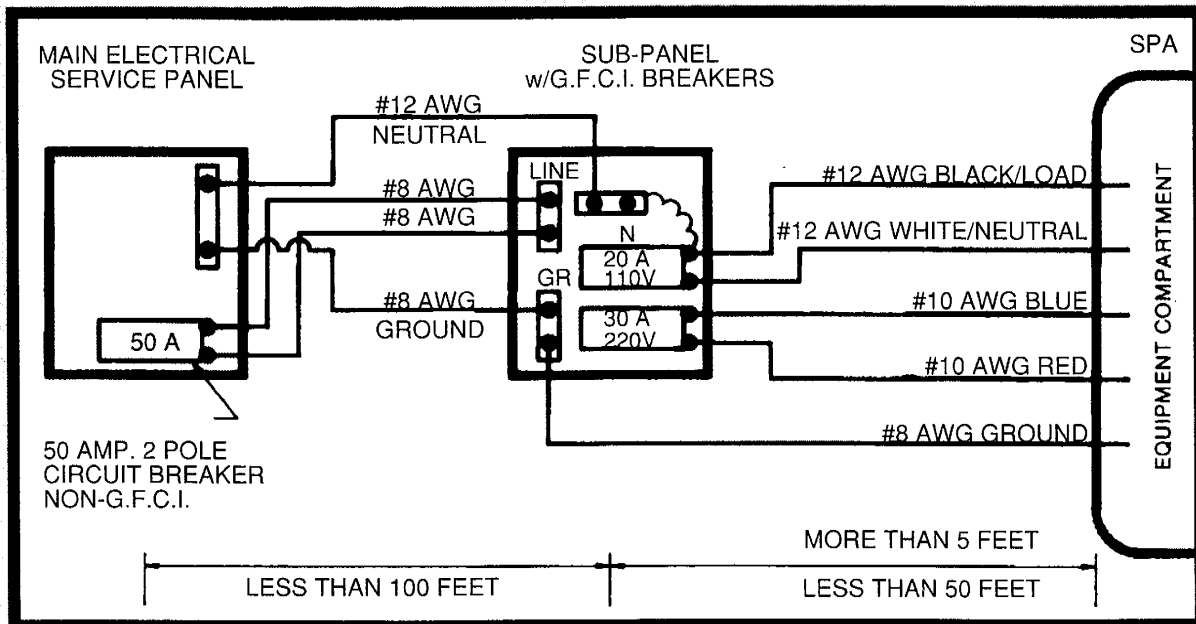

NOTE: ALL WIRING SHOULD BE COPPER

This sub-panel requires a 50 amp, single phase, 220 Volt, four wire service (two line, one neutral, one ground). The grounding conductor must be the same gauge as the line conductors, but no smaller than a #8 AWG. A #8 solid copper bond wire will also be required.

MOUNT THE SUB-PANEL ACCORDING TO LOCAL CODES IN THE VICINITY OF THE SPA, BUT NOT CLOSER THAN FIVE FEET.

### Installation Instructions

1. Remove the screws from the equipment access door and open the door to connect the electrical service.
2. Locate and remove the junction box cover. (On the GRANDEE, HIGHLIFE, and SOVEREIGN "IH" models, the junction box is attached to the control box. The junction box is located on the floor of the equipment compartment on the CLASSIC "FH" model.)
3. Route the supply conduit from the sub-panel into the spa's equipment compartment. (On the GRANDEE, HIGHLIFE and SOVEREIGN "IH" models, route the conduit through the access opening between the door frame and the equipment compartment. On the CLASSIC "FH" model, the supply conduit should be brought up through the opening in the floor of the equipment compartment. Install the supply conduit so as not to block the drain valve.)
4. Connect the supply conduit to the spa's flexible conduit which exits the bottom of the junction box on the GRANDEE, HIGHLIFE, and SOVEREIGN "IH" models, or connect it directly to the junction box on the CLASSIC "FH" model.

### Wiring Connections GRANDEE and HIGHLIFE Models

1. Connect the two solid #10 AWG copper wires from the 220 Volt, 30 amp, G.F.C.I. breaker to the #10 AWG, blue and red leads in the junction box.
2. Connect the two solid #12 AWG copper wires from the 220 Volt, 20 amp, G.F.C.I. breaker to the #12 AWG, blue and red leads in the junction box.
3. Connect the #12 AWG white copper wire lead in the junction box to the 220 Volt, 20 amp, G.F.C.I. breaker.

**NOTE:** The white neutral wire must be attached to the **LOAD** neutral on the 220 Volt, 20 amp breaker (not the neutral buss bar in the sub-panel). The white neutral wire from the breaker is then connected to the neutral buss bar.

4. Connect the green ground wire from the ground buss bar in the sub-panel to the green grounding screw in the wiring box. It is **ABSOLUTELY** essential that a good quality ground connection be made.

5. Bond the spa to all exposed metal equipment or fixtures, handrails, and concrete pad per N.E.C. Article 680.

### CLASSIC "FH" and SOVEREIGN "IH" Models

1. Follow instruction #1 above (GRANDEE/HIGHLIFE connections).
2. Connect the two solid #12 AWG copper wires (one white and one black) from the 120 Volt, 20 amp, G.F.C.I. breaker to the black and white leads in the junction box.

**NOTE:** The white neutral wire must be attached to the LOAD neutral on the 120 Volt breaker (not the neutral buss bar in the sub-panel). The white neutral wire from the breaker is then connected to the neutral buss bar.

Failure to connect the neutral wire to the 120 Volt G.F.C.I. breaker will cause the breaker to trip when power is supplied to the spa.

3. Follow the instructions #4 and #5 above (GRANDEE/HIGHLIFE connections). Replace the junction box cover and close the equipment access door.

**NOTE:** The spa will not operate unless the equipment door is completely closed and secured.

Turn on and test all breakers once the spa has been filled with water. Each of the G.F.C.I. breakers should be tested monthly. To test, simply push the "test" button on each of the G.F.C.I.s. The switch should click over to the trip position thus shutting off power to the circuit. If any of the G.F.C.I.s fail to operate in this manner, your spa may have an electrical malfunction, indicating the risk of electric shock. Turn off all circuits and do not use the spa until the malfunction has been corrected by an authorized service agent.

**WARNING:** Removing or bypassing the G.F.C.I. breakers in the sub-panel at any time will result in an unsafe spa and will void the warranty.

**IMPORTANT:** Should you ever find occasion to move or relocate your HOT SPRING SPA, it is essential you understand and apply its installation requirements.

**110 VOLT MODELS  
CLASSIC (Model F)  
SOVEREIGN (Model I)  
PRODIGY (Model H)  
JETSETTER (Model J)**

**Electrical Requirements**

The spa must be connected to a "dedicated" 110 Volt, 20 amp grounded circuit. The term "dedicated" means the electrical circuit is not being used for any other electrical items (patio lights, appliances, garage circuits, etc.). If the spa is connected to a non-dedicated circuit, overloading will result in "nuisance tripping" which requires resetting of the breaker switch at the house electrical breaker panel. The dedicated circuit must be properly wired; that is, it must have a 20 amp circuit breaker in the house breaker panel, #12 AWG or larger wire (including the ground wire) and the correct polarity throughout the circuit.

**NEVER CONNECT THE SPA TO AN EXTENSION CORD!**

A pressure wire connector is provided on the exterior surface of the control box, inside the spa. This is to permit the connection of a bonding wire between this point and any metal equipment, enclosures, pipe or conduit within five feet of the spa (if needed to comply with local building code requirements). The bonding wire must be at least a #8 AWG solid copper wire.

**Installation Instructions**

Each HOT SPRING SPA, 110 Volt model, comes equipped with approximately 15 feet of usable power cord (this is the maximum length allowed by Underwriters Laboratory and the National Electric Code). When the spa is installed, the power cord (on the redwood skirted models) will come out of the bottom of the equipment compartment door. On the CLASSIC, the power cord should be removed from the equipment compartment and brought out **under** the spa skirt (directly below the compartment door). When your electrician is installing the electrical outlet, please make sure it is located no further away than ten (10) feet from the equipment compartment door. For your safety, the National Electrical Code requires that the 20 amp single receptacle electrical outlet be located **no closer** than five (5) feet from the spa.

The Ground Fault Circuit Interrupter (G.F.C.I.) is located at the end of the power cord. This device is for your protection. It is very important to protect it from rain and other moisture. Once a month, with the plug connected to the power supply, push the test button located on the G.F.C.I. The reset button should pop out, shutting off power to the spa. Next, push the reset button back in. The button should stay in restoring power to the spa. If the Interrupter fails to operate in this manner, there may be a ground fault indicating

the risk of an electric shock. Disconnect the plug from the receptacle until the source of the malfunction has been identified and corrected by an authorized service agent.

**WARNING:** Removal of the G.F.C.I. from the spa power cord at any time will result in an unsafe spa and void the warranty.

**IMPORTANT:** Should you ever find occasion to move or relocate your HOT SPRING SPA, it is essential that you understand and apply its installation requirements.

**SERVICE NOTE:** *The equipment compartment access door of your spa is equipped with an electrical interlock device which automatically shuts off power to the spa anytime the door is opened. Once the door is closed, power is automatically restored. This electrical interlock device is for your safety and must not be removed or modified in any way.*

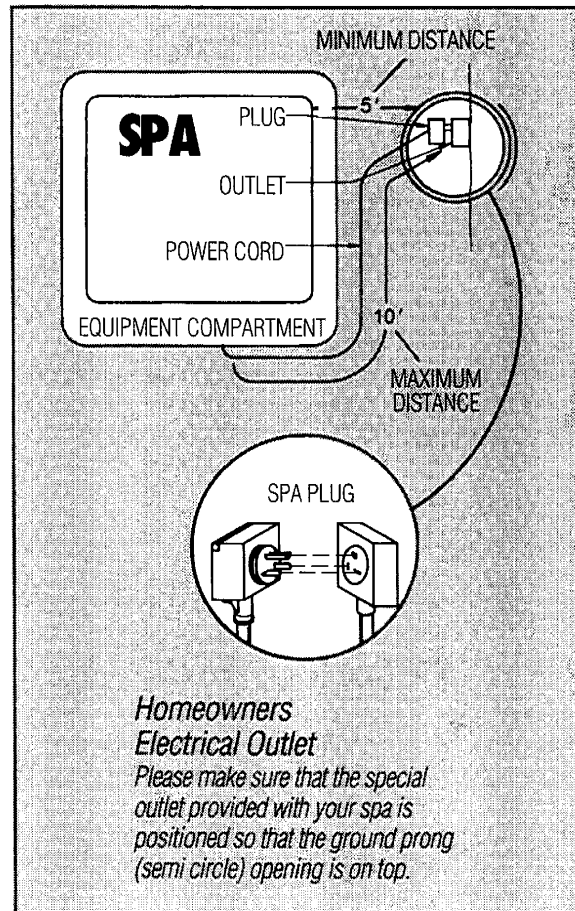

### III. SPA SPECIFICATIONS

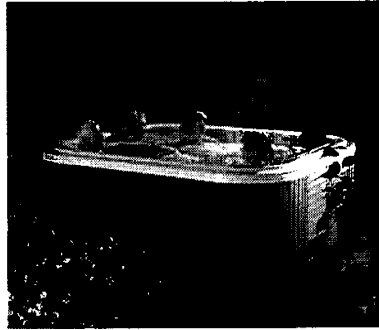

**GRANDEE® (Model G)**

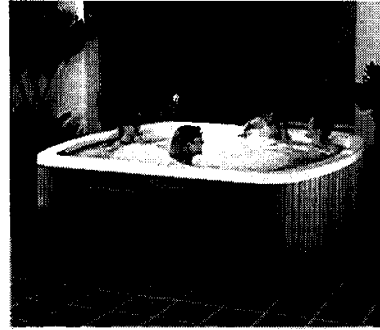

**HIGHLIFE® (Model K)**

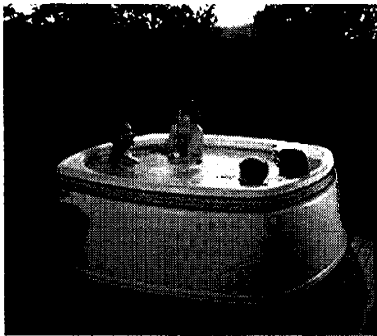

**CLASSIC™ (Models F & FH)**

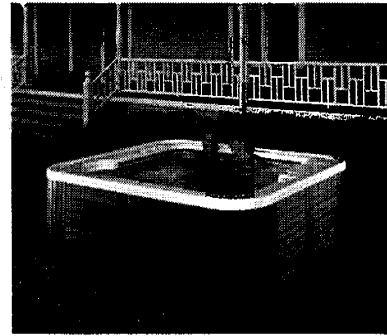

**SOVEREIGN® (Models I & IH)**

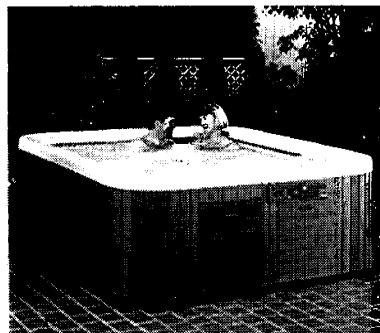

**PRODIGY® (Model H)**

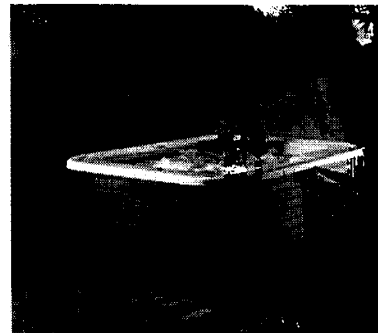

**JETSETTER® (Model J)**

## SPA SPECIFICATIONS

MODEL	HORIZONTAL DIMENSIONS	HEIGHT	EFFECTIVE FILTER AREA	HEATER (WATTS)	WATER CAPACITY (GAL)	DRY WEIGHT (LBS)	FILLED WEIGHT (LBS)	DEAD WEIGHT (LBS PER SQ. FT.)	ELECTRICAL REQUIREMENTS
GRANDEE (Model G)	7' 8" x 8' 3-1/2"	36-1/2"	150 Sq. Ft.	5,000 Watt	500 Gal	820 LBS	4,990 LBS	87 LBS PER SQ. FT.	220 Volt, 50 Amp Single Phase
HIGHLIFE (Model K)	8' 4" x 7' 2"	34"	120 Sq. Ft.	5,000 Watt	415 Gal	665 LBS	4,130 LBS	85 LBS PER SQ. FT.	220 Volt, 50 Amp Single Phase
CLASSIC (Model F)	7' 7-1/2" x 7' 8-1/2"	31"	90 Sq. Ft.	1,500 Watt	325 Gal	455 LBS	3,170 LBS	260* LBS PER SQ. FT.	110 Volt, 20 Amp Dedicated Circuit
CLASSIC (Model FH)	7' 7-1/2" x 7' 8-1/2"	31"	90 Sq. Ft.	5,000 Watt	325 Gal	455 LBS	3,170 LBS	260* LBS PER SQ. FT.	220 Volt, 50 Amp Single Phase
SOVEREIGN (Model I)	6' 4" x 7' 7"	29"	90 Sq. Ft.	1,500 Watt	300 Gal	530 LBS	3,035 LBS	75 LBS PER SQ. FT.	110 Volt, 20 Amp Dedicated Circuit
SOVEREIGN (Model IH)	6' 4" x 7' 7"	29"	90 Sq. Ft.	5,000 Watt	300 Gal	530 LBS	3,035 LBS	75 LBS PER SQ. FT.	220 Volt, 50 Amp Single Phase
PRODIGY (Model H)	5' 11" x 6' 10"	29"	90 Sq. Ft.	1,500 Watt	295 Gal	485 LBS	2,945 LBS	75 LBS PER SQ. FT.	110 Volt, 20 Amp Dedicated Circuit
JETSETTER (Model J)	5' x 6' 7"	27-1/2"	90 Sq. Ft.	1,500 Watt	205 Gal	415 LBS	2,150 LBS	75 LBS PER SQ. FT.	110 Volt, 20 Amp Dedicated Circuit

\*Spa weight of the CLASSIC is evenly distributed on a 42" x 42" platform (12.25 sq. ft. area).

**CAUTION:** Watkins Manufacturing Corporation suggests a structural engineer or contractor be consulted prior to the spa being placed on an elevated deck or platform.

SPA SPECIFICATIONS & ILLUSTRATIONS

FEATURES							FEATURES						
	GRANDEE	HIGHLIFE	CLASSIC	SOVEREIGN	PRODIGY	JETSETTER		GRANDEE	HIGHLIFE	CLASSIC	SOVEREIGN	PRODIGY	JETSETTER
<b>CONVENIENCE</b> Automatic Temperature Control- The HOT SPRING SPA achieves and maintains the temperature you select 24 hours a day and is always ready for use.	✓	✓	✓	✓	✓	✓	<b>PERFORMANCE</b> Adjustable hydrotherapy jets with silent, warm air induction.  (Quantity per spa)	✓	✓	✓	✓	✓	✓
Light with dimmer switch for night use.	✓	✓	✓	✓	✓	✓	MOTO-MASSAGE®moving hydrotherapy jet for the finest massage.	✓	✓	✓	✓		✓
Floor drain to provide thorough draining.	✓	✓	✓	✓	✓	✓	(Quantity per spa)	(2)	(1)	(2)	(1)		(1)
Pre-plumbed for HOT SPRING Ozone Purification System.	✓	✓	✓	✓	✓	✓	Adjustable JETSTREAM®powerful deep massage jet.	✓	✓	✓	✓	✓	
10-minute "Timed Jets" feature for timed spa use and ease of water maintenance.	✓	✓	✓	✓	✓	✓	(Quantity per spa)	(4)	(3)	(2)	(2)	(1)	
<b>SAFETY</b> Child resistant cover for control panel.	✓	✓	✓	✓	✓	✓	Weir and skimmer system to keep water surface clean.	✓	✓	✓	✓	✓	✓
Child resistant thermal cover tie-downs.	✓	✓	✓	✓	✓	✓	24-hour continuous-filtration.	✓	✓	✓	✓	✓	✓
Thermal protection on heaters and jet pump.	✓	✓	✓	✓	✓	✓	Highly-efficient filtration system for optimum water clarity.	✓	✓	✓	✓	✓	✓
Underwriters Laboratories (UL) Listed.	✓	✓	✓	✓	✓	✓	Durable and attractive thermal cover for economical operation.	✓	✓	✓	✓	✓	✓
Built-in ground fault circuit interrupter to help protect against electric shock.			(MODEL F)	(MODEL J)	✓	✓	<b>DURABILITY</b> Stainless steel heating system.	✓	✓	✓	✓	✓	✓
Electrical sub-panel with ground fault circuit interrupters provided with 220 volt spas.	✓	✓	(MODEL FH)	(MODEL JH)			ROVEL®Thermoplastic Spa Shell.	✓	✓	✓	✓	✓	✓
Double insulation on all electrical components.	✓	✓	✓	✓	✓	✓	Totally insulated with high-density, closed-cell urethane foam. Sealed with a solid urethane coating.	✓	✓	✓	✓	✓	✓
Temperature high limit protection.	✓	✓	✓	✓	✓	✓	Clear, all-heart redwood skirt.	✓	✓		✓	✓	✓
	✓	✓	✓	✓	✓	✓	Treated, ground-contact rated base support system.	✓	✓	✓	✓	✓	✓

## GRANDEE Model G Overhead view

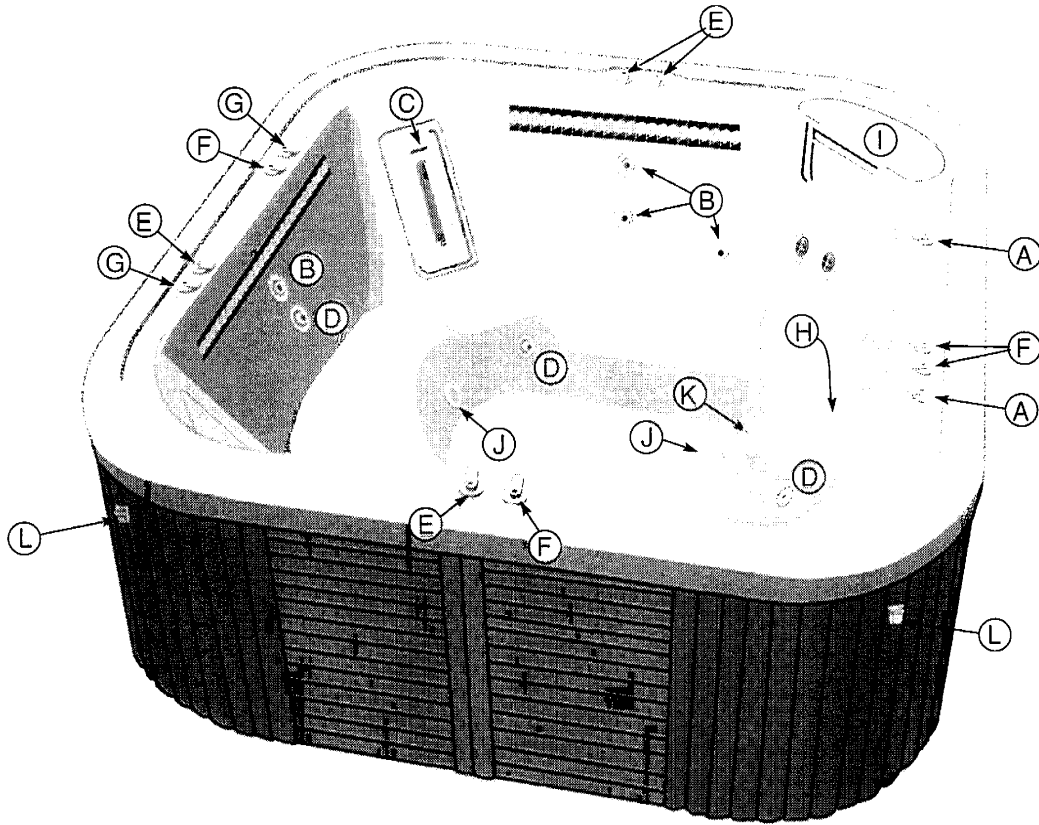

- |                                       |                                   |                                 |
|---------------------------------------|-----------------------------------|---------------------------------|
| A. JETSELECTOR Control                | G. MOTO-MASSAGE Air Control Valve | P. Spa High Limit Thermostat    |
| B. Adjustable Hydrotherapy Jet        | H. Heater Return                  | Q. Heater High Limit Thermostat |
| C. MOTO-MASSAGE Jet®                  | I. Filter Compartment             | R. Light                        |
| D. JETSTREAM Jet®                     | J. Spa Drain Inlet                | S. Junction Box                 |
| E. Hydrotherapy Jet Air Control Valve | K. Light Lens                     | T. Spa Drain Valve              |
| F. JETSTREAM Air Control Valve        | L. Thermal Cover Lock             | U. Flexible Electrical Conduit  |
|                                       | M. Jet Pump                       | V. Door Interlock               |
|                                       | N. 5 KW Heater                    | W. Timer Override Switch        |
|                                       | O. Heater Circulation Pump        |                                 |

### Equipment Compartment

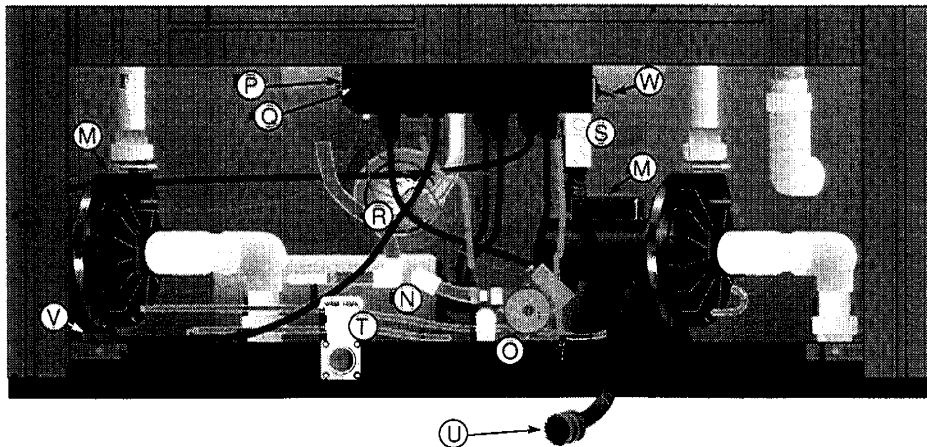

## HIGHLIFE Model K Overhead view

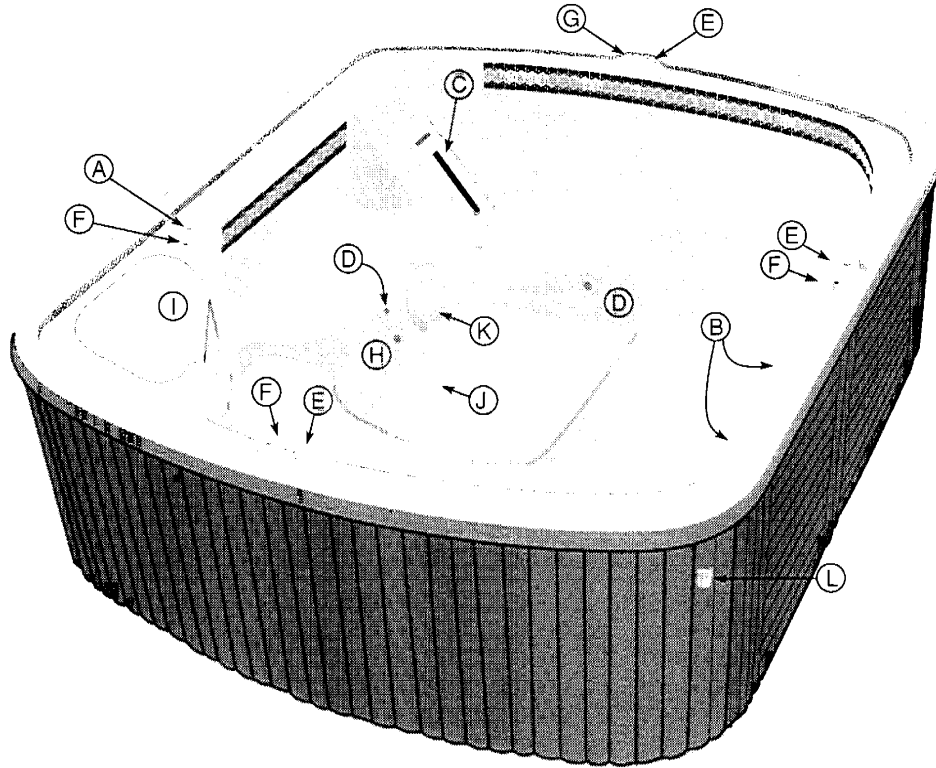

- |                                       |                                   |                                 |
|---------------------------------------|-----------------------------------|---------------------------------|
| A. JETSELECTOR Control                | G. MOTO-MASSAGE Air Control Valve | O. Heater Circulation Pump      |
| B. Adjustable Hydrotherapy Jet        | H. Heater Return                  | P. Spa High Limit Thermostat    |
| C. MOTO-MASSAGE Jet®                  | I. Filter Compartment             | Q. Heater High Limit Thermostat |
| D. JETSTREAM Jet®                     | J. Spa Drain Inlet                | R. Light                        |
| E. Hydrotherapy Jet Air Control Valve | K. Light Lens                     | S. Junction Box                 |
| F. JETSTREAM Air Control Valve        | L. Thermal Cover Lock             | T. Spa Drain Valve              |
|                                       | M. Jet Pump                       | U. Flexible Electrical Conduit  |
|                                       | N. 5 KW Heater                    | V. Door Interlock               |

### Equipment Compartment

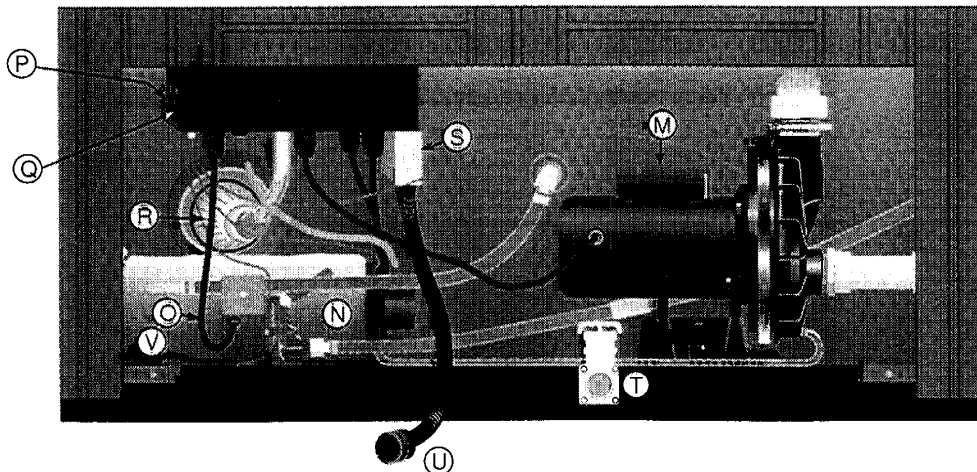



## CLASSIC Model F Overhead view

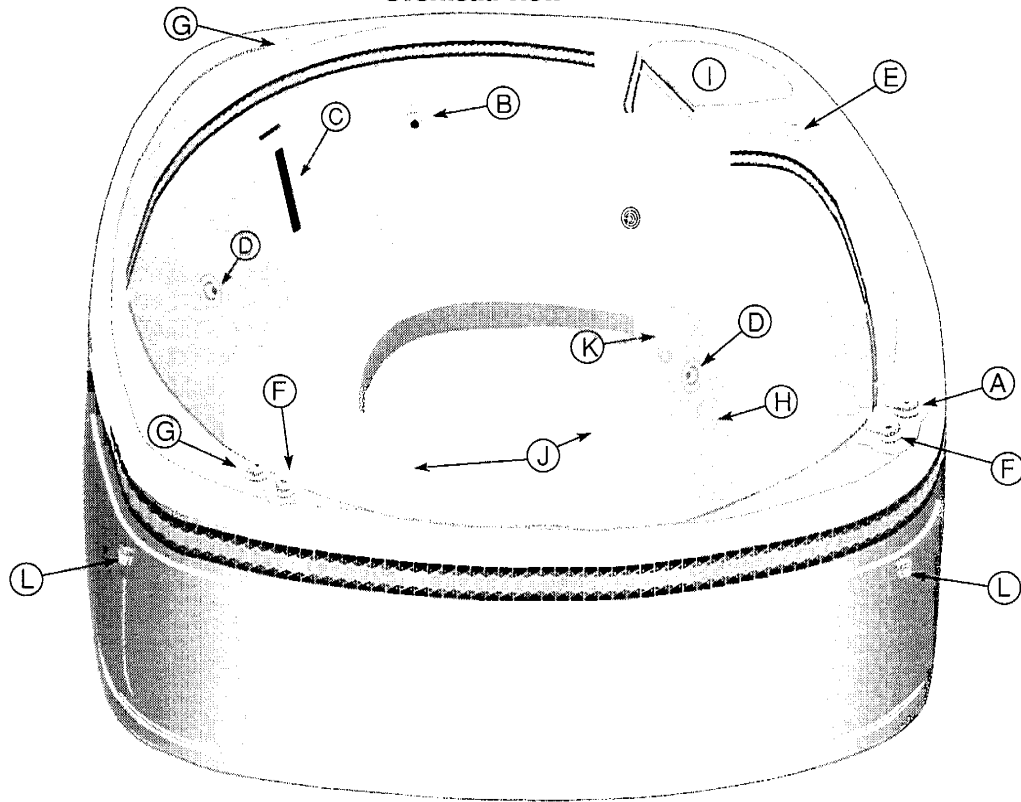

- |                                       |                                   |                                 |
|---------------------------------------|-----------------------------------|---------------------------------|
| A. JETSELECTOR Control                | G. MOTO-MASSAGE Air Control Valve | O. Heater Circulation Pump      |
| B. Adjustable Hydrotherapy Jet        | H. Heater Return                  | P. Spa High Limit Thermostat    |
| C. MOTO-MASSAGE Jet®                  | I. Filter Compartment             | Q. Heater High Limit Thermostat |
| D. JETSTREAM Jet®                     | J. Spa Drain Inlet                | R. Light                        |
| E. Hydrotherapy Jet Air Control Valve | K. Light Lens                     | S. G.F.C.I.                     |
| F. JETSTREAM Air Control Valve        | L. Thermal Cover Lock             | T. Spa Drain Valve              |
|                                       | M. Jet Pump                       | U. Door Interlock               |
|                                       | N. 1.5 KW Heater                  |                                 |

## Equipment Compartment (110 Volt)

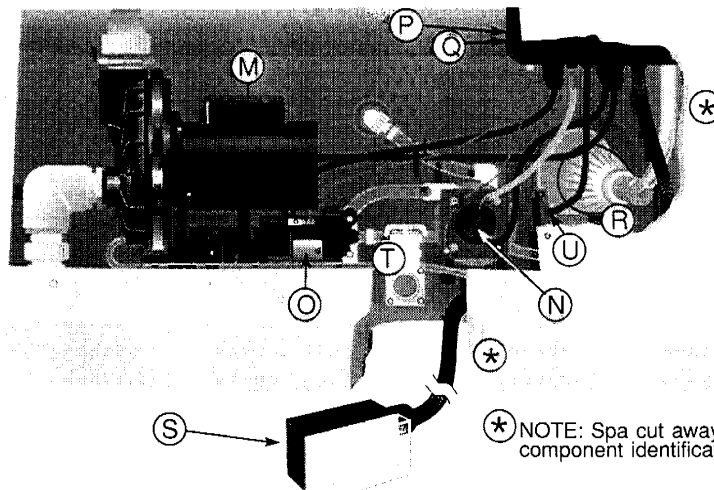

## SOVEREIGN Model I Overhead view

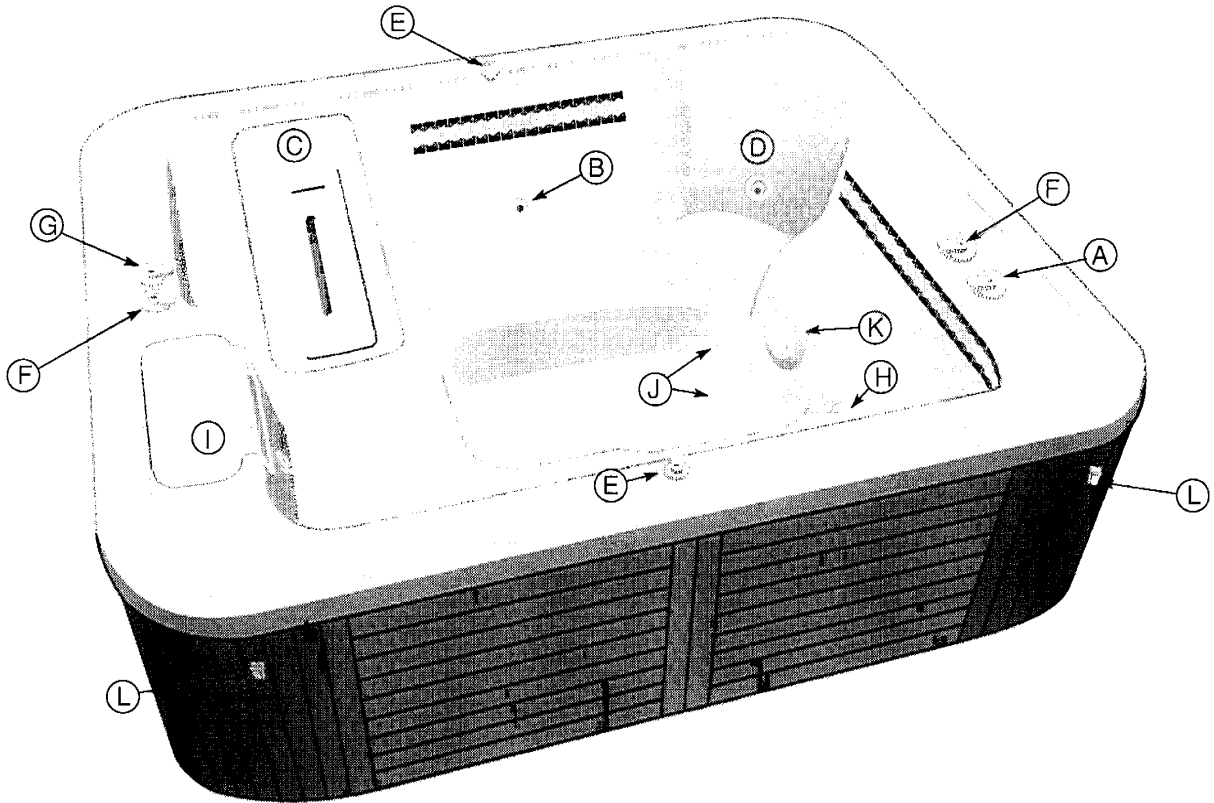

- |                                       |                                   |                                 |
|---------------------------------------|-----------------------------------|---------------------------------|
| A. JETSELECTOR Control                | G. MOTO-MASSAGE Air Control Valve | O. Heater Circulation Pump      |
| B. Adjustable Hydrotherapy Jet        | H. Heater Return                  | P. Spa High Limit Thermostat    |
| C. MOTO-MASSAGE Jet®                  | I. Filter Compartment             | Q. Heater High Limit Thermostat |
| D. JETSTREAM Jet®                     | J. Spa Drain Inlet                | R. Light                        |
| E. Hydrotherapy Jet Air Control Valve | K. Light Lens                     | S. G.F.C.I.                     |
| F. JETSTREAM Air Control Valve        | L. Thermal Cover Lock             | T. Spa Drain Valve              |
|                                       | M. Jet Pump                       | U. Door Interlock               |
|                                       | N. 1.5 KW Heater                  |                                 |

### Equipment Compartment (110 Volt)

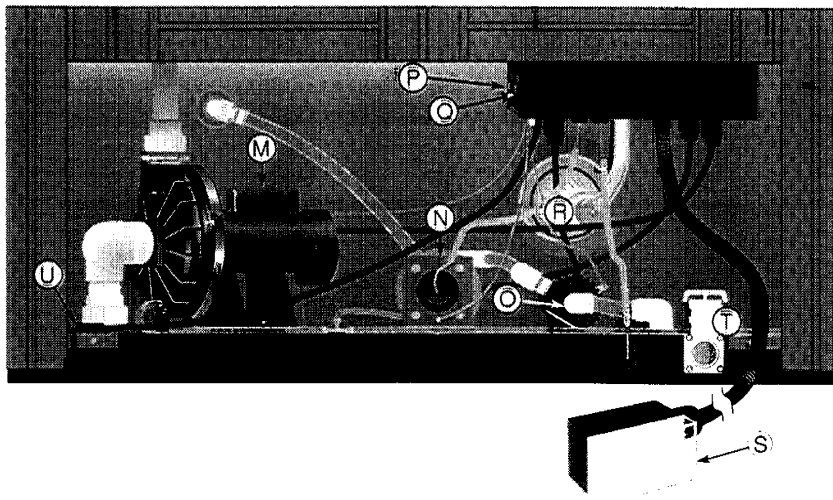

**CLASSIC Model FH**  
**Equipment Compartment (220 Volt)**

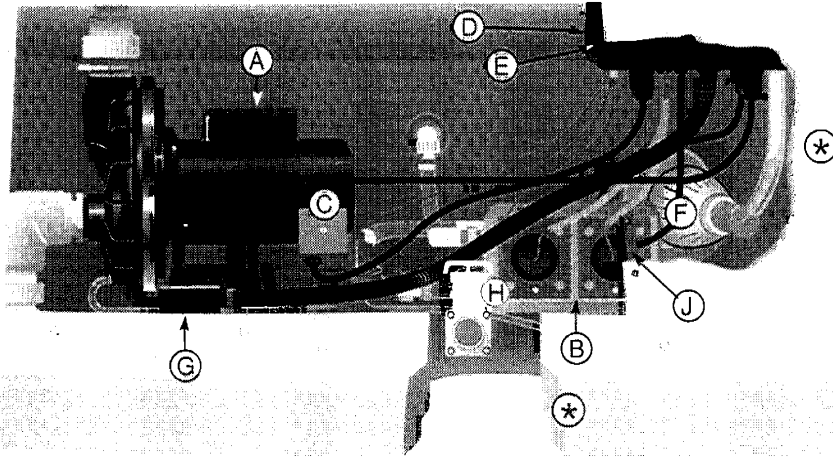

(\*) NOTE: Spa cut away to assist with component identification.

- |                                 |                                |
|---------------------------------|--------------------------------|
| A. Jet Pump                     | F. Light                       |
| B. 5 KW Heater                  | G. Junction Box                |
| C. Heater Circulation Pump      | H. Spa Drain Valve             |
| D. Spa High Limit Thermostat    | I. Flexible Electrical Conduit |
| E. Heater High Limit Thermostat | J. Door Interlock              |

**SOVEREIGN Model IH**  
**Equipment Compartment (220 Volt)**

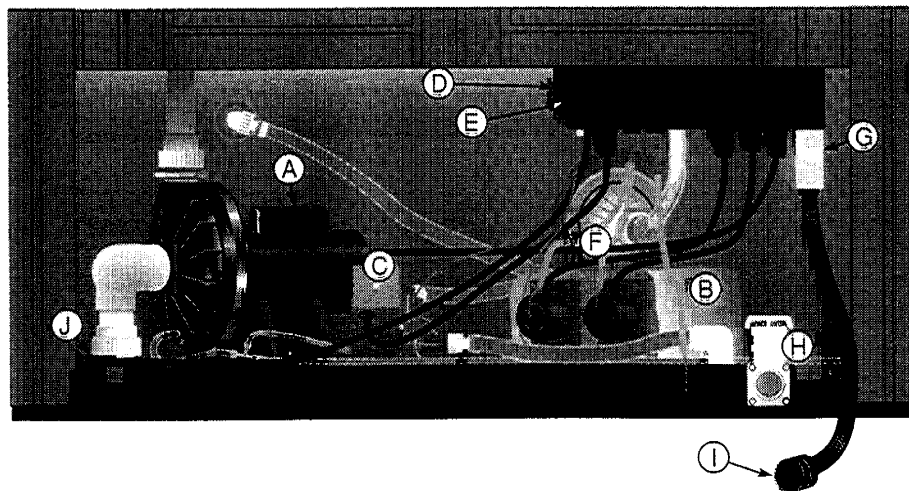

## PRODIGY Model H Overhead view

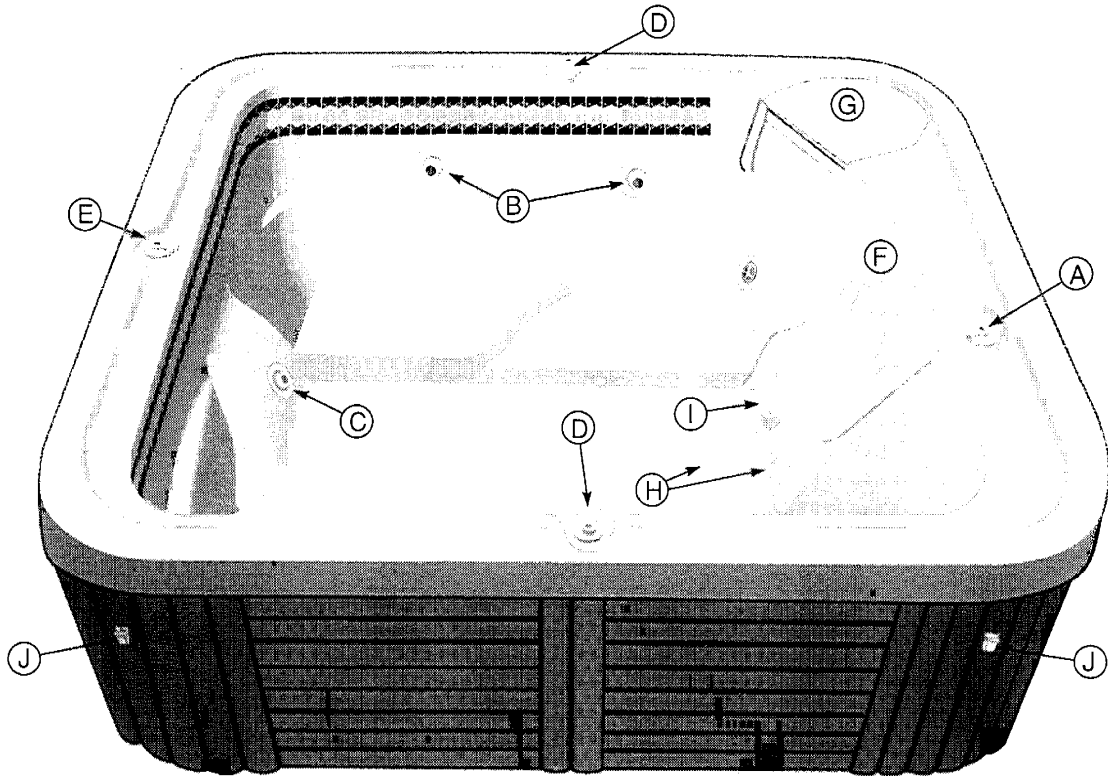

- |                                       |                            |                                 |
|---------------------------------------|----------------------------|---------------------------------|
| A. JETSELECTOR Control                | F. Heater Return           | N. Spa High Limit Thermostat    |
| B. Adjustable Hydrotherapy Jet        | G. Filter Compartment      | O. Heater High Limit Thermostat |
| C. JETSTREAM Jet®                     | H. Spa Drain Inlet         | P. Light                        |
| D. Hydrotherapy Jet Air Control Valve | I. Light Lens              | Q. G.F.C.I.                     |
| E. JETSTREAM Air Control Valve        | J. Thermal Cover Lock      | R. Spa Drain Valve              |
|                                       | K. Jet Pump                | S. Door Interlock               |
|                                       | L. 1.5 KW Heater           |                                 |
|                                       | M. Heater Circulation Pump |                                 |

### Equipment Compartment

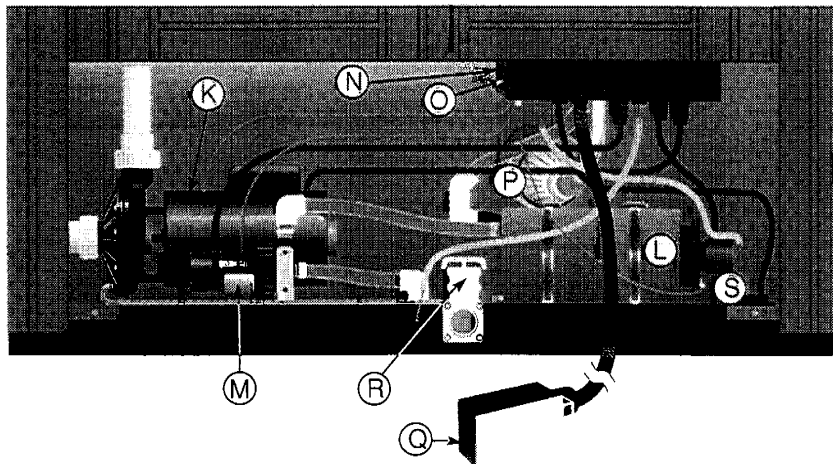

## JETSETTER Model J Overhead view

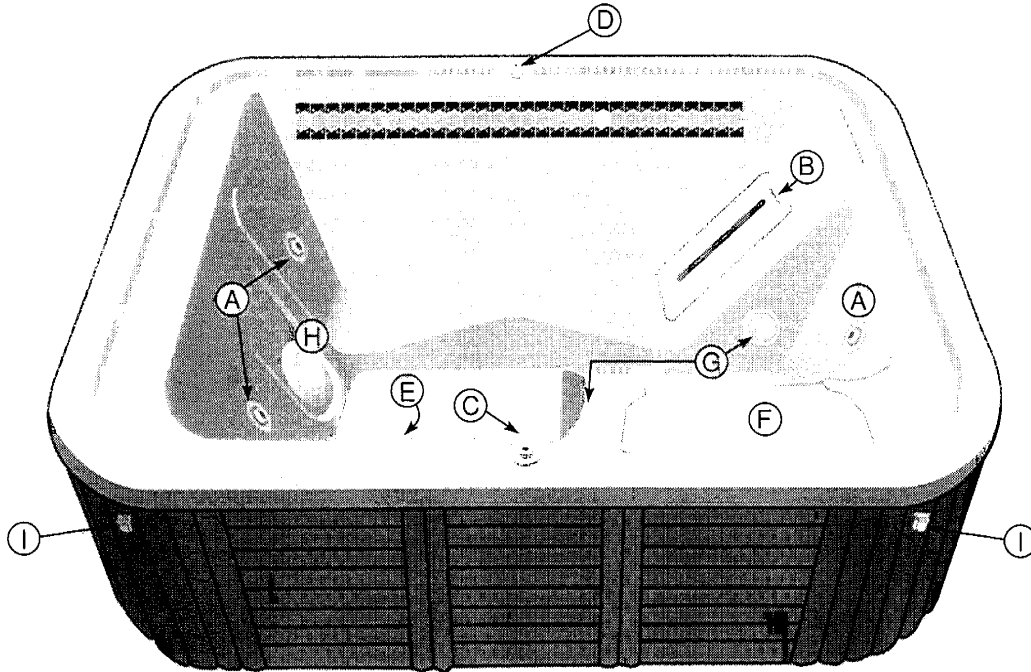

- |                                       |                              |                                 |
|---------------------------------------|------------------------------|---------------------------------|
| A. Adjustable Hydrotherapy Jet        | F. Filter Compartment        | N. Heater High Limit Thermostat |
| B. MOTO-MASSAGE Jet®                  | G. Spa Drain Inlet           | O. Light                        |
| C. Hydrotherapy Jet Air Control Valve | H. Light Lens                | P. G.F.C.I.                     |
| D. MOTO-MASSAGE Air Control Valve     | I. Thermal Cover Lock        | Q. Spa Drain Valve              |
| E. Heater Return                      | J. Jet Pump                  | R. Door Interlock               |
|                                       | K. 1.5 KW Heater             |                                 |
|                                       | L. Heater Circulation Pump   |                                 |
|                                       | M. Spa High Limit Thermostat |                                 |

### Equipment Compartment

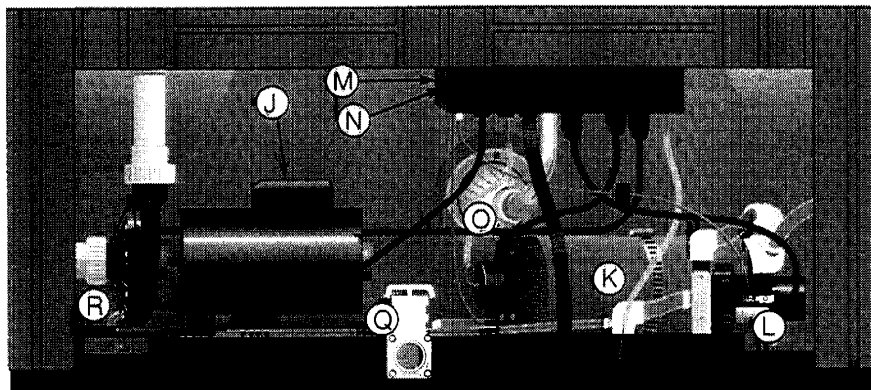

## **IV. OPERATING INSTRUCTIONS**

### **GENERAL INFORMATION**

HOT SPRING Portable Spas are manufactured in two different electrical versions. The largest spa models, the GRANDEE and HIGHLIFE, are available only with a 220 Volt continuous heating system. The middle of the line spa models, the CLASSIC and SOVEREIGN, are available in either the standard 110 Volt system or a 220 Volt continuous heating system. The smaller water capacity spas, the PRODIGY and JETSETTER, are available only in the standard 110 Volt system. Each electrical system is designed to operate a specific way — the systems are not convertible.

#### **GRANDEE (Model G) HIGHLIFE (Model K)**

The GRANDEE and HIGHLIFE come equipped with a sub-panel which contains two 220 Volt G.F.C.I. circuit breakers. The sub-panel and spa must be “hardwired” using appropriate wire, conduit and fittings by a licensed electrician.

The GRANDEE's dual, 1 HP jet pump system, can operate each half of the spa separately, or both halves simultaneously. The multiple air control valves and JETSELECTOR Controls allow for several combinations of stationary jets, MOTO-MASSAGE JETS and JETSTREAMS.

The HIGHLIFE utilizes a single 2 HP jet pump to operate either its six jet (1 MOTO-MASSAGE and 5 stationary jets) system or its triple JETSTREAM system. As with the GRANDEE, multiple air control valves allow for a number of user options.

Both the GRANDEE and HIGHLIFE have stainless steel heating systems (both heater housing and elements) that are insulated for energy efficiency. The heating system circulation pump draws less than 1 amp running 24 hours a day for continuous filtration.

The control thermostat (TEMP dial on the control panel) continually senses the temperature of the spa water and regulates the cycling of the heater. Because both HOT SPRING SPA models utilize a 220 Volt, 5 KW heating system, the heater will turn on while the jet pumps are operating (after a 1 degree temperature drop) to help maintain the water temperature. Factors such as the number of people using the spa, the ambient temperature and the length of time the jet pumps are operated, will all contribute to the heating system's ability to maintain the water temperature.

#### **CLASSIC (Model F) SOVEREIGN (Model I) PRODIGY (Model H) JETSETTER (Model J)**

These four spa models are manufactured with a 110 Volt, cord and plug connected electrical system. The heating system consists of a single thermostatically controlled 1,500 watt (1.5 KW) stainless steel heater enclosed in an insulated stainless steel housing and an energy efficient low-flow heater circulation pump. The hydrotherapy jet system is powered by a large 1 HP, energy efficient jet pump. A 110 Volt electrical system is considered an “either/or” hydrotherapy system. That is, either the hydrotherapy jet pump can be operated or the heating system. The heater does not operate at the same time the hydrotherapy pump is operating. The low-flow heater circulation pump will run continuously (even when the jet pump is operating) as part of the 24 hour continuous filtration system.

#### **CLASSIC (Model FH) SOVEREIGN (Model IH)**

All 220 Volt CLASSIC and SOVEREIGN HOT SPRING SPAS come equipped with a sub-panel which contains two G.F.C.I. breakers (1)-110 Volt and (1)-220 Volt. The sub-panel and spa must be “hard-wired” using appropriate wire, conduit, and fittings by a licensed electrician.

The 220 Volt circuit supplies power to thermostatically controlled, dual 2,500 watt (2 x 2.5 KW = 5 KW total), stainless steel heaters enclosed in an insulated, stainless steel housing. The 110 Volt circuit supplies power to the hydrotherapy jet pump, heater circulation / continuous filtration pump, and all electrical controls and switches. With a 220 Volt heating system, the heater will turn on while the jet pump is operating (after a 1 degree temperature drop) to help maintain the water temperature. Factors such as the number of people using the spa, the ambient temperature, and length of time the jet pump is operated, will all contribute to the heating system's ability to maintain the water temperature.

It is important to note that even though the heating system circulation pump runs continuously as part of the continuous 24 hour filtration system, the heaters only turn on when the control thermostat senses a drop in the spa water temperature.

## START-UP PROCEDURES

The water level of your HOT SPRING SPA should be maintained approximately four inches below the top of the spa. The bottom of the tile line of the CLASSIC or the middle of the tile on all wood skirted models can be used for easy reference.

### CAUTIONS:

- Do not fill the spa with hot water as damage to the control thermostat or tripping of the high-limit thermostat may result.
- Do not connect power to an empty spa.
- Before using your spa after filling, super chlorinate the spa water to ensure all bacteria and contaminants have been oxidized. (See Water Quality and Maintenance Section.)

**Step 1 :** Fill the spa with tap water. (The main drain plug which was included with the spa's Owner's Package should be installed during the initial installation of the spa.)

**NOTE:** Watkins Manufacturing Corporation does not recommend the spa be filled with "softened" water.

**Step 2:** Once the spa has been filled with water, the equipment compartment door closed and secured, power must be supplied to the spa.

- 110 Volt Models (F,I,H,J)—Connect the plug to the house receptacle and push in the "reset" button on the G.F.C.I.
- 220 Volt Models (G,K,FH,IH)—Open the door of the electrical sub-panel and "reset" the two G.F.C.I. breakers. Close and secure the sub-panel door.

**Step 3 :** The jet pump(s), heating system, and all internal plumbing will prime automatically during the filling of the spa with water. To check the operation of the jet system (and purge any remaining air from the heating system) push in Jet Switch #1 (also #2 switch for the GRANDEE) and wait one minute.

**GRANDEE Note :** Jet Switch #1 operates the left jet pump and Jet Switch #2 (identified as TIMED JETS) operates the right jet pump. If you decide to override the Timed Jet function on the GRANDEE, refer to the Control Panel information in this section.

Once the hydrotherapy jet system is fully operational (as indicated by strong, non-surgings jets), priming of the spa is complete.

**IMPORTANT:** Be sure the air control valves are open by turning each one to the plus (+) symbol and that the JETSELECTOR Control lever is pointing to the GREEN dot to get the jets fully operational.

**SERVICE NOTE:** Weak or surging jets are an indication of a low water level condition or clogged filter cartridges.

**Step 4: IMPORTANT:** Sanitize (super-chlorinate) and chemically balance (adjust pH) the spa water by following the procedures listed in the Water Quality and Maintenance Section. The jet switch marked TIMED JETS should be used for the 10 minute "shock treatment".

**Step 5 :** Once the spa plumbing and pumps have been primed, the water sanitized, and the jet pump has shut off, the thermal cover should be put on the spa. Always secure the cover in place using the cover tie-downs whenever the spa is not being used.

**Step 6 :** Push in and turn the "TEMP" dial on the control panel to number 3. Within 18 to 24 hours, the water will reach a temperature of approximately 100 degrees F. A water temperature not exceeding 104 degrees F can be achieved by setting the "TEMP" dial not higher than number 5. Please note, the numbers around the temperature dial are reference points to be used during temperature adjustments. They do not reflect the actual water temperature of the spa. If you find that you prefer cooler water, rotate the temperature control toward the next lower number. Conversely, if you prefer warmer water, rotate the temperature control toward the next higher number. Remember that a small change of the temperature control will yield a difference of several degrees, so make small adjustments until you find your preferred temperature. Allow several hours between adjustments. Thereafter, the water will remain within one degree of your selected temperature.

## **HYDROTHERAPY JET SYSTEM GENERAL INFORMATION**

### **GRANDEE**

The GRANDEE's dual hydrotherapy jet pumps, when used either separately or simultaneously, provide the ultimate in user options. Each jet pump provides water pressure through one of the spa's three hydrotherapy jet systems (selected with the JETSELECTOR Control).

### **HIGHLIFE CLASSIC SOVEREIGN PRODIGY JETSETTER**

These five spa models utilize a large hydrotherapy pump to power their multiple jet systems. On the HIGHLIFE, CLASSIC and SOVEREIGN models, the JETSELECTOR Control can be used to direct water pressure through one of the spa's three hydrotherapy jet systems. On the PRODIGY, the water can be directed through one of the spa's two hydrotherapy jet systems by using the JETSELECTOR Control.

**OPERATION NOTE:** In addition to using the JETSELECTOR Control, the intensity of the MOTO-MASSAGE JETS, JETSTREAM jets, and stationary hydrotherapy jets can be adjusted by the use of their designated air control valves. For convenience, the air controls which regulate the JETSTREAM are identified by a BLUE color dot on the air control lever. A GREEN color dot on an air control lever indicates it regulates either a MOTO-MASSAGE JET or a set of stationary jets. Each air control is marked with a plus (+) or minus (-) symbol to indicate either increasing or decreasing air volume through a specific jet or set of stationary jets. The JETSELECTOR Control is identified with both a GREEN and a BLUE color dot. If the JETSELECTOR Control lever is pointing towards the GREEN dot, then water is being directed to the MOTO-MASSAGE JET and stationary jets. If the JETSELECTOR Control lever is pointing towards the BLUE dot, then water is being directed to the JETSTREAM jets.

## **GRANDEE JET SYSTEMS**

**SYSTEM I** • Three stationary hydrotherapy jets and one MOTO-MASSAGE JET. The JETSELECTOR Control lever should be pointing towards the GREEN dot on the control base.

**SYSTEM II** • All water pressure can be directed through the dual JETSTREAM jets. The JETSELECTOR Control lever should be pointing towards the BLUE dot on the control base.

**SYSTEM III** • Three stationary hydrotherapy jets, one MOTO-MASSAGE JET, and two JETSTREAM jets. The JETSELECTOR Control lever should be set approximately halfway between the BLUE and GREEN dots on the control base.

**NOTE:** Because of the additional jet orifices with the SYSTEM III setting, the water pressure will be softer. Remember each jet pump can operate a different hydrotherapy jet system simultaneously.

## **HIGHLIFE JET SYSTEMS**

**SYSTEM I** • Six stationary hydrotherapy jets and one MOTO-MASSAGE JET. The JETSELECTOR Control lever should be pointing towards the GREEN dot on the control base.

**SYSTEM II** • All water pressure can be directed through the triple JETSTREAM jet system. The JETSELECTOR Control lever should be pointing towards the BLUE dot on the control base.

**SYSTEM III** • Six adjustable hydrotherapy jets, one MOTO-MASSAGE JET, and three JETSTREAM jets. The JETSELECTOR Control lever should be set approximately halfway between the BLUE and GREEN dots on the control base.

**OPERATION NOTE:** Because of the additional jet orifices with the SYSTEM III setting, the water pressure will be softer.

## **CLASSIC AND SOVEREIGN JET SYSTEMS**

**SYSTEM I** • Stationary hydrotherapy jets and MOTO-MASSAGE JET(S). The JETSELECTOR Control should be pointing towards the GREEN dot on the control base.

**SYSTEM II** • All water pressure can be directed through the dual JETSTREAM jet system. The JETSELECTOR Control should be pointing towards the BLUE dot on the control base.

**SYSTEM III** • Water pressure can be directed through all jets (stationary hydrotherapy jets, MOTO-MASSAGE JET(S), and JETSTREAM jets). The JETSELECTOR Control should be set approximately halfway between the GREEN and BLUE dots on the control base.



**NOTE:** Because of the additional jet orifices with the SYSTEM III setting, the water pressure will be softer.

## PRODIGY AND JETSETTER JET SYSTEMS

With the PRODIGY and JETSETTER models, the intensity of the jets can be adjusted by the use of the designated air control valve. On the PRODIGY, there is an air control valve to adjust the intensity of the JETSTREAM and an air control valve for each set of stationary jets (two jets per side). On the JETSETTER, there is an air control valve for the simultaneous adjustment of the MOTO-MASSAGE JET and lounge stationary jet and one control for the two remaining stationary jets.

### MOTO-MASSAGE JET® (Not Available on PRODIGY)

The MOTO-MASSAGE JET automatically travels up and down in a sweeping motion. This gentle reciprocating action simulates the natural stroking effects of a manual massage. The intensity and speed of the MOTO-MASSAGE JET can be adjusted by either restricting or opening the air control valve, or by turning the JETSELECTOR Control to its midpoint.

The MOTO-MASSAGE JET has been factory adjusted to provide maximum hydrotherapy. This jet has been designed and engineered to achieve full vertical travel with the designated air control valve open. Should the MOTO-MASSAGE JET not achieve full vertical travel and the problem has **not been** identified as a closed air control valve or clogged filter cartridge, then your HOT SPRING SPA Service Center should be contacted.

**SERVICE NOTE:** *If the MOTO-MASSAGE JET suddenly ceases to move while in use (but the water pressure remains strong) and the air control valve is open, then the jet air line may have pulled away from the main air supply line. To inspect:*

1. Using a standard screwdriver, remove the face plate screwhead covers.
2. Remove the two screws which secure the MOTO-MASSAGE face plate to the guide body. Then remove the face plate.
3. Remove the four guide body screws and remove the guide body.
4. Reach into the jet recess and locate the thin, unbraced tube. In the correct position, it should be attached to the plastic air line nipple located at the back of the recess. If it is not, then the air line should be gently pushed onto the nipple. *Note, do not push the tube on so far as to cause the MOTO-MASSAGE JET braces to bind.*
5. Reinstall the guide body (no adjustment is necessary) and the face plate.

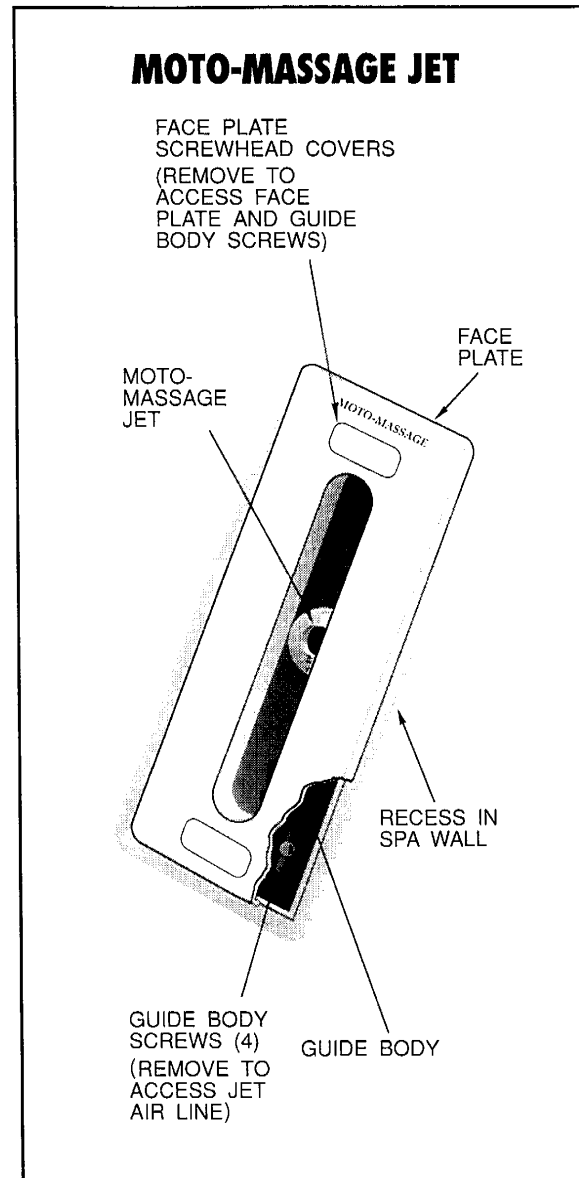

**SERVICE NOTE:** *A slow or non-moving MOTO-MASSAGE JET may indicate the filter cartridge pores are being obstructed with dirt, body oils, or calcification. Follow the filter cartridge cleaning procedures in the Spa Care and Maintenance Section of this manual.*

## **JETSTREAM®** (Not Available on JETSETTER)

The JETSTREAM is best described as a large-orifice, hydrotherapy jet designed to provide maximum massage on a specific area of the body. It is located in the lower part of the spa to afford optimal access for the massaging of feet, legs, buttocks, and lower back.

For a jet orifice of this size (1/2") to produce a powerful deep massage, a large volume of water is required. A low-friction diverter valve enables you to switch from the MOTO-MASSAGE/STATIONARY JET system to the JETSTREAM hydrotherapy system. With a turn of the JETSELECTOR Control which is located on the top surface of the spa over the equipment compartment, the JETSTREAM system will come to full power. (The control lever should be pointing towards the BLUE dot.) The JETSTREAM air control valve can be used to control the intensity of the jet. The JETSTREAM jet utilizes a large nozzle which can be directionally adjusted to concentrate the water flow on specific areas of the body.

**IMPORTANT:** Hydrotherapy "Venturi type" jets require water velocity to create air induction into the water jet stream. Should you move the JETSELECTOR Control lever halfway between the GREEN and BLUE dots, water from the jet pump will now be diverted through all jet systems. As a result, there will be reduced water agitation, slow or non-moving MOTO-MASSAGE JETS, and low-pressure stationary jets. This type of spa operation is quite normal and may be considered a "soak" setting.

### **STATIONARY JETS**

The stationary hydrotherapy jets are adjustable. The intensity of these jets is determined by the volume of air being induced into the jet chambers and mixing with the water stream. The air control valve can be utilized to change the intensity of a set of stationary jets simultaneously.

**NOTE:** Allowing the hydrotherapy jet pump to operate for long uninterrupted periods of time (more than 2 hours) with the thermal cover in place, will cause a rise in the spa water temperature. The spa high limit thermostat will shut off the spa when the water approaches 118 degrees F. The switch will have to be

reset manually (once the water has cooled to approx. 100 degrees F) in order for the spa to operate. If this situation occurs, please refer to the Service Information Section of this manual. This safety device is for your protection.

**SERVICE NOTE:** *The hinged equipment compartment door on the HOT SPRING SPA CLASSIC is constructed of a molded ABS/ROVEL plastic sheet. Over a period of time the spa may settle (or the door may be extremely rigid because of cold weather) which will result in the screw holes on the door not aligning with screw holes around the compartment perimeter. If this situation occurs, the door may be difficult to secure completely. To align the screw holes, place your knee just below the center of the door. While pushing gently with your knee (to spread the door slightly), insert the door screws and thread them finger-tight. Remove your knee and then secure the screws completely.*

### **CONTROL PANEL**

- A. **JETS:** The jet button located on the left side of the control panel and labeled "Jets" and #1 is used to activate the hydrotherapy jet pump continuously (or the left jet pump on the GRANDEE). To activate the switch, simply push the "Jets" button once; pushing it a second time will deactivate the pump circuit (shut off the jet pump). This switch also has a priority feature which means it can be used to cancel and "override" the Timed Jets mode without causing the jet pump to shut off. Also, because of the priority feature, when this switch is activated, it must be deactivated prior to the Timed Jets switch being engaged.
- B. **TIMED JETS:** The jet button labeled "Timed Jets" and #2 allows for timed soaks and easy water maintenance. This "Timed Jets" button features a red indicator light which will illuminate when the pump is in the timer mode. To engage the timer, simply push the Timed Jets button which will start the 10-minute timer. After 10 minutes, the hydrotherapy jet pump will automatically shut off. The timer may be overridden prior to the end of the 10-minute period by either pushing the "Timed Jets" button a second time, or by pushing the "Jets" button.

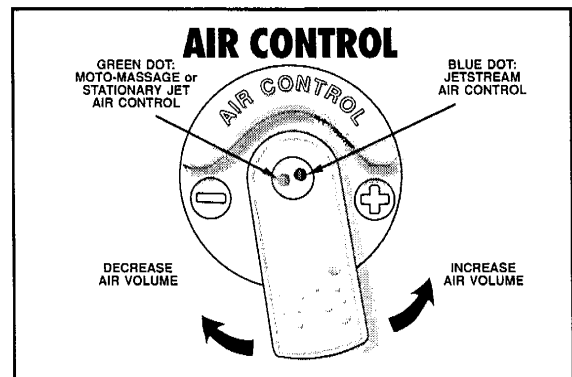
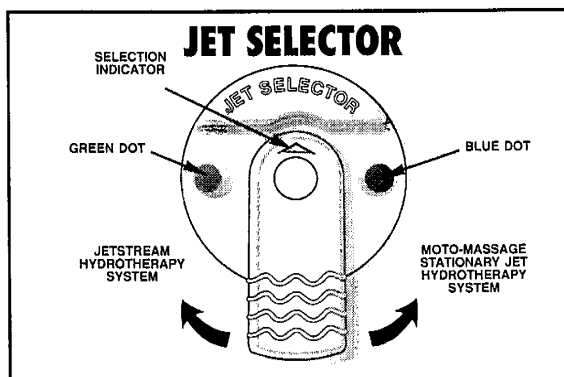

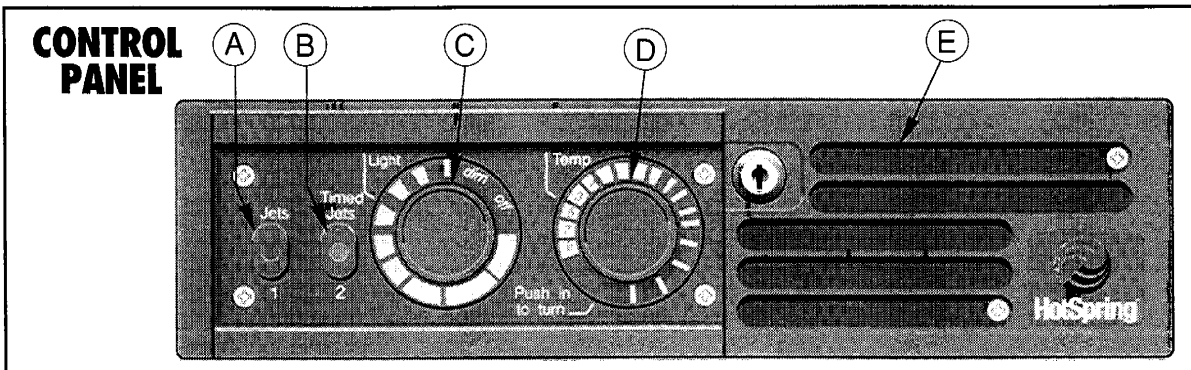

**OPERATION NOTES:** 1) The "Timed Jets" button on the GRANDEE will control the right jet pump. If you wish to have the ability to operate both jet pumps continuously (and not utilize the 10-minute time feature), then the timer can be overridden. To switch off the timer feature, first disconnect power to the spa (trip the circuit breakers in the sub-panel) and then open the equipment access door. On the right side of the control box will be a toggle switch labeled Timed Jets ON/OFF. Switch the toggle handle to the "OFF" position to override the timer function. Close and secure the equipment access door and reactivate power to the spa; 2) The accuracy of the timer is: 10 minutes + "0" or - "1" minute.

- C. **LIGHT CONTROL:** Use this dial to turn on and control the intensity of the spa light.
- D. **TEMP CONTROL:** The Temp control is used to regulate the water temperature of the spa. To use, push in the dial and turn it to the number 3. As stated in the Start-Up Procedures, a water temperature not exceeding 104 degrees F can be achieved by setting the "Temp" dial not higher than number 5. Please note, the numbers around the dial are reference points to be used during temperature adjustments. They do not reflect the actual water temperature of the spa. Once the dial has been set and the water temperature stabilized, then the water will remain within one degree of your selected temperature.
- E. **AIR VENT:** The air vent allows for air circulation through the equipment compartment to avoid pump overheating during extended spa use or during hot weather days. During sub-freezing temperatures, the air vent should be insulated with a vent plug to maintain the energy-efficiency of the spa (refer to Prevention of Freezing Instructions).

## LIGHT

All HOT SPRING Portable Spas come equipped with a dimmer controlled light to enhance nighttime use. The light uses a standard 100 watt outdoor PAR lamp. Should you wish to change the lamp, follow these simple steps:

1. Disconnect the spa from the power supply. On 110 Volt models remove the power cord (plug) from the house receptacle and on 220 Volt models trip the two G.F.C.I. breakers in the sub-panel.
2. Remove the screws securing the equipment access door; raise and secure the door in an open position.
3. Locate the light fixture below the electrical control box and gently unscrew the bulb (and heat guard assembly if applicable).
4. Replace with a 75 or 100 watt lamp.

**IMPORTANT:** All spa models except for the JETSETTER and PRODIGY utilize a lamp heat guard. To install the lamp guard on a new bulb:

- Engage the light bulb on two of the three "bulb retainers".
- Carefully snap the bulb into the third bulb retainer. This will hold the bulb firmly in the lamp heat guard.

**NOTE:** Some force may be required to snap the bulb into the third bulb retainer.

5. The bulb and lamp heat guard assembly now can be installed into the spa. Screw the bulb and guard assembly into the lamp socket inside the spa equipment compartment.

**NOTE:** Due to the large size of the bulb and guard assembly, you may have to negotiate the assembly around the components and insulation in the equipment compartment to install. Center the bulb so it is directed through the light lens.

6. Close and secure the equipment access door and restore power to the spa. (Reconnect the power cord on 110 Volt models or "Reset" the G.F.C.I. breakers on 220 Volt models.)

**IMPORTANT:** Do Not Use A Light Bulb In Excess of 100 Watts!

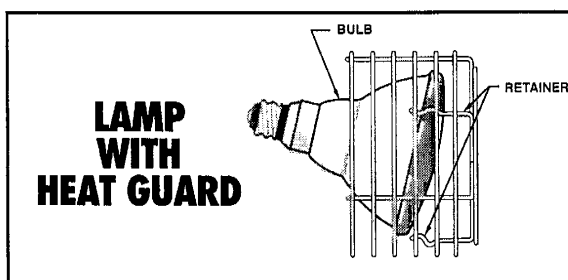

# V. SPA CARE AND MAINTENANCE

## GENERAL INFORMATION

Your HOT SPRING SPA is manufactured from the highest quality, most durable materials available. Even so, Watkins Manufacturing Corporation recommends that a spa care and maintenance program be followed to increase your comfort and maintain the spa's reliability. The spa care and maintenance program you develop will ultimately determine how long your spa or its individual components will last. The following maintenance section when adhered to, will help you protect your investment.

## DRAINING THE WATER

Detergent residues from bathing suits as well as soap film from your body may gradually accumulate in the water. Normally, in two to three months the water will become sudsy and should be replaced.

**NOTE:** Showering without using soap prior to entering the spa or only using a "rinse" cycle when laundering your bathing suit will help to avoid detergent residue in the spa water.

### To drain your spa:

1. Disconnect the spa from the power supply by one of the two following methods:  
**110 Volt Models-** Disconnect the power cord from the house receptacle. Set the power cord in an elevated position so as not to allow water to enter the G.F.C.I. plug housing during draining of the spa.  
**220 Volt Models-** Trip all of the G.F.C.I. breakers located in the sub-panel.

**NOTE:** Disconnect power to the Ozone Purification System (if applicable).

2. Remove the screws from the equipment access door; raise and secure the door. Locate the main drain valve for the spa and remove the threaded drain plug. Install the threaded garden hose adapter which was included with the spa's Owner's Package. Attach the inlet of a garden hose to the drain valve (to avoid flooding the foundation surrounding the spa) and route the outlet of the hose to an appropriate draining area.

**IMPORTANT:** If your spa is equipped with a ROVEL Thermal Cover, it should be open during draining of the spa.

**NOTE:** Spa water with a high sanitizer level may harm plants and grass.

4. Open the valve by pulling up on the handle and the spa will drain by gravitational flow.
5. **IMPORTANT:** All HOT SPRING SPA models will drain almost completely through the main drain valve. This includes the equipment such as the hydrotherapy jet pump, heater circulation pump, and heating system. Any water remaining within the plumbing or equipment after draining will only need to be removed if the spa is being "winterized".
6. When empty, inspect the spa shell and clean as required. (Follow Care of the Exterior Finish/ROVEL Spa Shell Instructions.)
7. Close the drain valve, remove the threaded hose adapter and reinstall the threaded drain valve plug.
8. Lower the equipment access door and replace the screws.
9. Refill the spa BEFORE restoring power to it.

**IMPORTANT:** Always clean the filter cartridges each time the spa has been drained for cleaning.

## FILTER MAINTENANCE

As with any water filtering system, the filter cartridges may become clogged with particles or with calcification that will result in reduced water flow. In your HOT SPRING SPA, it is important to maintain a clean, unobstructed filtering system. This not only provides the maximum performance from the hydrotherapy jets, but allows the 24 hour filtration system to function effectively. Watkins Manufacturing Corporation recommends the filter cartridges be cleaned (either spraying clean with water or soaking to dissolve minerals) EVERY MONTH!

**WARNING:** Failure to maintain the cartridges in a clean, unobstructed manner will result in reduced water flow through the heater assembly which may cause the Heater High Limit Thermostat to "trip". If this high limit "trip" occurs during sub-freezing temperatures and goes unnoticed, the spa water may freeze. Any damage to the spa (due to freezing) caused as a result of poor maintenance (stated under misuse or abuse of the HOT SPRING SPA Limited Warranty), will not be covered by your spa warranty.

## FILTER CARTRIDGE REMOVAL & INSTALLATION INSTRUCTIONS (All Models)

1. Remove and carefully set aside the filter compartment cover.
2. Remove any floating items from within the filter compartment.
3. Turn the filter retainer handle (located on the top of the filter cartridge) counterclockwise until the retainer can be removed from the filter standpipe.
4. Remove the filter retainer and cartridge.

**SERVICE NOTE:** Do not remove the filter standpipe when the spa is full of water. Debris may find its way into the internal plumbing which may result in blockage of the hydrotherapy or continuous filtration system.

5. To reinstall the filter cartridge, reverse the order in which it was removed. Do Not Overtighten!

## FILTER CARTRIDGE CLEANING INSTRUCTIONS

1. Place the filter cartridge on a clean foundation and spray each cartridge clean using a garden hose. It may be necessary to rotate the cartridge while spraying so as to thoroughly remove any debris lodged between the filter pleats.
2. After allowing it to dry, inspect the filter cartridge for calcium deposits (scaling) or an oil film.

**SERVICE NOTE:** Extremely hard water will cause a rapid buildup of minerals on the cartridge. Additionally, the use of oil-base spa water scents (and body oils) may coat the filter cartridge. The use of a garden hose will not remove either the mineral deposits or the oil film. A filter cartridge cleaner to soak the cartridges in is available from your HOT SPRING SPA dealer.

**WARNING:** Do not use the spa with the filter cartridge(s) or filter standpipe removed!

## FILTER COMPARISON CHART

SPA MODEL/I.D.	QTY. FILTER CARTRIDGES	CARTRIDGE SIZE SQ. FT.	TYPE OF SYSTEM
GRANDEE (Model G)	5	30 Sq. Ft.	A
HIGHLIFE (Model K)	4	30 Sq. Ft.	C
CLASSIC (Model F & FH)	3	30 Sq. Ft.	B
SOVEREIGN (Model I & IH)	3	30 Sq. Ft.	B
PRODIGY (Model H)	3	30 Sq. Ft.	B
JETSETTER (Model J)	3	30 Sq. Ft.	B

## TYPE OF SYSTEM

A— Multiple filter cartridges are secured vertically in the filter compartment by filter standpipes and pressure retainers. One cartridge is dedicated to the spa's 24-hour continuous-filtration system and two cartridges are dedicated to **each** of the two jet pump/hydrotherapy systems.

B— Multiple filter cartridges are secured vertically in the filter compartment by filter standpipes and pressure retainers. One cartridge is dedicated to the spa's 24-hour continuous-filtration system and two cartridges are dedicated to the jet pump/hydrotherapy system.

C— Multiple filter cartridges are secured vertically in the filter compartment by filter standpipes and pressure retainers. One cartridge is dedicated to the spa's 24-hour continuous-filtration system and three cartridges are dedicated to the jet pump/hydrotherapy system.

## CARE OF THE EXTERIOR FINISH

### ROVEL™ Spa Shell

Your HOT SPRING SPA has a high quality ROVEL plastic shell. Stains and dirt generally will not adhere to this surface. Cleaning of the surface should be done with a non-abrasive, non-sudsing cleaner. Your spa dealer stocks a surface cleaner designed specifically for spa surfaces. Baking soda can also be used for minor surface cleaning. The use of a soft rag or a nylon scrubber should easily remove most dirt buildups.

#### SERVICE NOTES:

1. *Iron and copper can stain the ROVEL spa shell if allowed to go unchecked. Your HOT SPRING SPA dealer stocks a Stain and Scale Inhibitor to use if your spa water has high concentrations of dissolved minerals. A spa polish can be used after surface cleaning to "shine" the ROVEL spa shell.*
2. *Use care not to get baking soda on the redwood spa skirts as discoloration may occur.*

**IMPORTANT:** Always thoroughly rinse off any spa shell cleaning agent. Some surface cleaners contain eye and skin irritants. Keep all cleaners out of reach of children and use care when applying.

### Redwood Spa Skirt

The spa skirts on HOT SPRING SPAS are made of the finest quality redwood. A good quality wood sealer or natural color wood oil should be applied twice a year or as needed to keep the skirts looking new. Like all wood products, prolonged exposure to outdoor weather conditions may accelerate deterioration. In such cases it will be necessary to reseal the skirts more often. Discoloration or aging of the wood skirts is considered natural and is not covered by the five year surface warranty.

**NOTE:** Your HOT SPRING SPA dealer may stock the Original Factory Finish or may suggest another spa skirt sealer that is available in your area.

## CARE OF THE THERMAL COVER "Vinyl" Thermal Cover

The vinyl thermal spa cover is an attractive, durable foam insulation product. Monthly cleaning and conditioning is recommended to maintain its beauty. To clean and condition the vinyl cover:

1. Remove the cover from the spa and gently lean it against a wall or fence.
2. With a garden hose, spray the cover to rinse away and loosen dirt or debris.
3. Using a large sponge and/or a soft bristle brush, and using a very mild soap solution (1 teaspoon dishwashing liquid with 2 gallons water) or

baking soda, scrub the vinyl in a circular motion. Use care not to let the vinyl dry (with a soap film on it) before it can be rinsed clean.

**IMPORTANT:** To avoid soap getting into the spa water or baking soda getting on the redwood skirt (which may cause black spots or streaks on the redwood), the spa cover should not be on the spa during cleaning.

4. Scrub the perimeter and side flaps of the cover. Rinse clean.
5. Be sure to rinse off the bottom of the cover (use no soap), and wipe it clean with a dry rag.
6. To condition the vinyl after cleaning, apply a thin film of saddle soap (available at most stores) and follow the directions on the container.

**SERVICE NOTE:** *To remove tree sap, use lighter fluid (not charcoal lighter **but** the kind used in cigarette lighters). Use sparingly, and rinse with a saddle soap solution immediately afterwards and wipe dry.*

#### IMPORTANT REMINDERS:

- **DO** remove snow buildup to avoid breakage to the foam core.
- **DO** lock cover straps to secure cover to the spa when spa is not in use.
- **DO NOT** drag or lift the spa cover using either the flaps or the tie-down straps.
- **DO NOT** walk, stand, or sit on the foam insulated cover.
- **DO NOT** use any chemicals or cleaners except those recommended by Watkins Manufacturing Corporation or its Authorized Sales and Service Dealer.

### ROVEL Thermal Cover

The ROVEL thermal cover is a durable, foam insulation product designed for year-round use. As with the soft vinyl cover, the ROVEL cover will retain its beauty if it is maintained correctly. This includes monthly cleaning, periodic polishing, and preventive maintenance during the winter.

To ensure many seasons of use, the following use and care instructions should be noted:

### **How To Use The Cover**

1. With the tie-down straps unfastened, stand at either the left or right front corner of the spa.
2. Place one hand under the edge of the cover (your right hand if **standing** on the left, your left hand if **standing** at the right front corner).
3. Place your other hand on the bottom pivot arm (the longest arm on the hinge/gas cylinder assembly).
4. While lifting with one hand (the one under the edge of the cover), take a few steps towards the back of the spa. Your second hand can be used to gently push the cover backwards and also to slow it down so it does not hit hard on the ground behind the spa.

**NOTE:** The cover is designed to open from front to back, do not twist or attempt to use the cover in a way it is not designed.

5. Fasten the cover lock assembly.

### **To Close The Cover**

1. Unfasten the cover lock assembly.
2. Stand on either side of the spa, gently pull down on the cover.

**WARNING:** Do not close the cover by pulling on the pivot arms; finger entrapment may occur.

3. Fasten the tie-down straps.

### **Use Of The ROVEL Cover In Winter**

Though the ROVEL cover is structurally the strongest spa cover available, it is not designed to withstand excessive or concentrated weights. For that reason sweep off any snow from the top of the cover before it is allowed to accumulate.

**NOTE:** When using your spa during sub-freezing temperatures, the ROVEL spa cover may freeze to the ground (when in the open position). If this situation occurs, simply splash a small amount of the hot spa water on the frozen area to break the bond.

**SERVICE NOTE:** Damage to the cover trim strip or rubber bumpers could occur if you attempt to close the cover if it is frozen to the ground.

### **Use Of The ROVEL Cover In Winds**

In addition to providing user privacy, the ROVEL cover also makes an ideal wind-break. When mounted correctly, it is designed to withstand up to a 35 mph direct wind blast. Regardless, Watkins Manufacturing Corporation recommends the cover

lock assembly **always** be used when the cover is in the open position.

**IMPORTANT:** The cover lock assembly is a safety device. It is designed to "break away" should the wind factor be excessive or if leverage is placed on the hinge/gas cylinder assembly while the cover is in the upright position (attempting to close the cover while it is still locked, etc.). Should the lock "break away", it will be necessary to refasten the two halves of the lock assembly.

### **To Clean And Polish The ROVEL Cover**

1. Using a garden hose, spray the cover to rinse away any loose dirt or debris.
2. Apply a liquid spa surface cleaner (available from your HOT SPRING SPA dealer) with a cloth or a sponge to the ROVEL surface.

**WARNING:** Some surface cleaners contain eye and skin irritants. Keep all spa cleaners out of reach of children and use care when applying.

**NOTE:** If the surface cleaner drips onto the redwood skirt, rinse off with water.

3. After allowing the cleaner to set on the surface for a minute or two to soften the dirt, scrub the cover with a sponge or soft bristle brush.
4. Thoroughly rinse the cover off after cleaning.
5. If you wish to polish the cover, wipe it dry with a towel or soft cloth. Apply spa shell polish per the manufacturer's printed instructions. Allow to dry before removing the polish and buffing.
6. Use a damp cloth to remove any dirt from the cover arms, gas cylinder, or the trim strip.

**WARNING:** The ROVEL cover is not designed to be walked, stood, or sat on; keep children off of the cover! Always lock the cover in place after use.

**IMPORTANT:** Whenever the spa is not in use, it is essential that the thermal cover be in place. When filled, this ensures effective temperature maintenance and economical operation. When empty, this prevents potential damage to the surface finish of the interior walls which can result from the excessive heat of the sun. This type of damage is specifically excluded from warranty protection. It is recommended that the thermal cover tie-downs always be used to discourage access to the spa by unsupervised children and to minimize heat loss.

## VACATION CARE INSTRUCTIONS

If you plan to be away, follow these instructions to ensure the water quality of your spa is maintained:

### Short Time Periods (3-5 Days):

1. Adjust the pH by following the instructions outlined in the Water Quality and Maintenance Section.
2. Sanitize the water by following the "super-chlorination" procedures also listed in the Water Quality Section.
3. Lock your thermal cover in place using the tie-downs.
4. Upon your return, sanitize the water (super-chlorinate, if necessary), and balance the pH.

### Long Time Periods (5-14 Days):

1. At least one (1) day before you leave, push in and turn the Temperature Control counterclockwise all the way until it stops at the lowest identification mark on the control. This setting should represent an **approximate** water temperature of 82-85 degrees F.

**IMPORTANT NOTE:** Spa water oxidizers such as dichlor chlorine maintain their level of effectiveness substantially longer in warm water (80 degrees to 85 degrees F) than in hot water (101 degrees to 104 degrees F).

Prior to leaving:

2. Adjust the pH as required.
3. Sanitize the water by following the SUPER-CHLORINATION procedures.
4. Upon your return, check the level of sanitation of your spa water. If the chlorine test kit reads "0" and you have been gone an extended period of time, SUPER-CHLORINATE the spa water to ensure all organisms or algae are oxidized. Push in and turn the Temperature Control clockwise to return it to the original setting. The spa water will be safe for you to use once the Free Chlorine Residual has dropped below 5.0 ppm.

**NOTE:** If you will not be using your spa for an extended period of time (in excess of 12-14 days) and an outside maintenance service (or neighbor) is not available to assist with the water maintenance, draining or winterizing of the spa is recommended.

## PREVENTION OF FREEZING

The HOT SPRING SPA has been designed and engineered for year-round use in any climate. In some areas, extremely cold temperatures (below 10 degrees F) combined with strong wind (chill factor) may cause partial freezing of the jet pump (even though the water inside the spa remains at the selected temperature). The energy efficiency of the spa may also decrease during these cold periods as the heater will cycle more frequently. To avoid most problems associated with component freezing, the 24-hour continuous-filtration system has been designed with bleed lines connecting the jet pumps with the heating/filtering system. Thus, as the heating system circulation pump runs continuously, cooling water in the different systems is continually evacuated and replaced by warm spa water. As an additional precaution against partial freezing of some of the components, the equipment compartment door and air intake vent can be insulated. This can be done by installing a fiberglass insulation blanket (available from your HOT SPRING SPA dealer) inside the compartment door and a plug in the air vent. This additional insulation will help to maximize the spa's energy efficiency.

**NOTE:** When warmer weather returns (approx. 60-70 degrees F), the insulating blanket and vent plug must be removed to prevent overheating of the jet pump.

Please contact your HOT SPRING SPA dealer for additional information or to order the Insulation Blanket / Plug Kit.

## WINTERIZING

In very cold weather you may not want to venture outside to use your spa. In this case, you may move it to a heated area, or leave it as is until the weather warms. If you do leave the spa unused for a long period of time in severely cold weather, you should drain the spa to avoid accidental freezing due to a power or equipment failure.

Your local authorized dealer can perform the following winterizing steps if you do not wish to attempt them yourself:

1. Disconnect the spa from the power supply by one of the two following methods:

**110 Volt Models** - Disconnect the power cord from the house receptacle. Set the power cord in an elevated position so as not to allow water to enter the G.F.C.I. plug housing during draining of the spa.

**220 Volt Models** - Trip all of the G.F.C.I. breakers located in the sub-panel.

**NOTE:** Disconnect power to the Ozone Purification System (if applicable).

2. Remove the screws from the equipment access door; raise and secure the door.



3. Locate the main drain valve for the spa and remove the plug. Install the threaded garden hose adapter which was included with the spa's Owner's Package. Attach the inlet of a garden hose to the drain valve and route the outlet of the hose to an appropriate draining area.
4. Open the valve and the spa will drain by gravitational flow.
5. All HOT SPRING SPA models will drain almost completely through the main drain valve. This includes the equipment such as the hydrotherapy jet pump, heater circulation pump, and heating system.
6. Remove the filter cartridges, clean and store the cartridges in a dry place.
7. **IMPORTANT:** Sponge out any residual water from inside the spa and the recesses of the MOTO-MASSAGE and filter compartments. Wipe all surfaces dry.

#### **SERVICE NOTES:**

1. *Refer to MOTO-MASSAGE Section for face plate removal instructions.*
2. *Leave the main drain valve open approximately 1/4" during the winterizing months.*
3. *You may wish to remove the filter standpipe to facilitate draining of the filter compartment.*  
*NOTE: Ensure no debris is present on the floor of the compartment prior to removal of the filter standpipe (large debris may block freeze drain bleed lines if allowed to enter the plumbing lines). When replacing, do not overtighten.*
8. *If your spa has a vinyl thermal cover, cover it with a large board to distribute the weight from snow and ice.*

#### **To Reactivate:**

Reinstall the filter cartridges, close the main drain and reinstall the drain plug. Follow the Start-Up Procedures to get your HOT SPRING SPA operational.

**IMPORTANT:** Always keep spa covered when not in use (empty or full).

## VI. WATER QUALITY AND MAINTENANCE

### INTRODUCTION

Just as the care and maintenance of your spa is important to maintaining its value and ensuring trouble-free performance, water quality and maintenance is important for user enjoyment and protection. It is important to note that while at first you may be overwhelmed by the amount of information contained in this section, spa water maintenance actually consists of three separate easy-to-develop programs. They are:

- Sanitizing and maintaining a safe level of sanitizer in the spa water.
- Balancing the pH and maintaining the recommended mineral content levels in the spa water.
- Achieving and maintaining water clarity.

Once you have had an opportunity to read this section and apply the information during the first 30 days of spa ownership, you will be well on your way to developing a Water Quality and Maintenance Program. It will be based upon your spa use (frequency and duration), user load (number of spa users), rate of contamination (again dealing with number of spa users and frequency), and the beginning mineral content of your tap water. Should you have any questions regarding spa water maintenance that have not been answered in this section or by your authorized HOT SPRING SPA dealer, please contact Watkins Manufacturing Corporation's Service Department at the number listed on the first page of this Owner's Manual.

### GENERAL INFORMATION

Safe, comfortable and clean spa water isn't difficult to achieve. However, a total spa water maintenance program is required. This program encompasses not only water circulation and filtration, but also correct spa water chemistry achieved through water sanitation and mineral balance. Watkins Manufacturing Corporation recommends the following spa sanitation and pH control procedures (based on average spa use in an ideal situation). Additionally, your HOT SPRING SPA dealer is a trained professional who can assist you in developing a start-up and maintenance program based on your "tap water" mineral content and the average user load of your spa. Check with your dealer; many offer in-house water analysis to assist in resolving specific water chemistry problems.

Spa water sanitation is chemically achieved with CHLORINE (Sodium/Dichloro-S-Triazinetrione **or** Sodium Dichloro-Isocyanurate). Mineral balance and pH control are chemically achieved with mineral additives. Filtration is mechanically achieved by pumping water through a filter with tiny pores. Bacteria and viruses are so small they pass right through the filter pores. They must be killed by chemical actions; i.e. chlorine. Both sanitation and filtration are necessary for water clarity. Maintaining the correct pH and mineral balance of the spa water will ensure a long life for the electrical components and reduce spa surface scaling.

**IMPORTANT:** Your HOT SPRING SPA warranty specifically **excludes** surface or component damage caused by poor water chemistry, the improper use or application of chemicals, the use of non-approved chemicals, or the non-control of pH.

**NOTE:** In addition to using chlorine as a water sanitizer for your spa, your dealer may also recommend a HOT SPRING Ozone Purification System. This system is designed to greatly enhance the quality of the spa water by using ozone for its "oxidizing power" and chlorine for a measurable chemical residual. Watkins Manufacturing Corporation recommends that a chemical maintenance program which is based on recognized and documented industry standards should still be followed when using an ozone purification system to assure water sanitation and the highest quality purified water is achieved.

Contact your authorized HOT SPRING SPA dealer for more information on the Ozone Purification System.

**IMPORTANT:** Any spa shell, plumbing, electrical system, thermal cover, or other component failure resulting from the addition of any non-approved alternate water sanitation or purification device, heating system or the modification of the original equipment is not covered by your HOT SPRING SPA warranty.

## WATER CHEMISTRY TERMINOLOGY

The following chemical terms will be used in this Water Quality and Maintenance Section. Understanding their meaning will help you to better understand the water maintenance process.

**Bromamines:** Compounds formed when bromine combines with nitrogen from body oils, urine, perspiration, etc. Unlike chloramines, bromamines have no pungent odor and are effective sanitizers.

**Bromine:** A sanitizer in the same chemical family as chlorine. Bromine is commonly used in stick, tablet, or granular form.

**NOTE:** See #2 in DOs and DON'Ts of Spa Water Maintenance for additional information.

**Calcium Hardness:** The amount of dissolved calcium in spa water. This should be approximately 100-200 ppm. High levels of calcium can cause cloudy water and scaling. Lower levels can harm the equipment.

**Chloramines:** Compounds formed when chlorine combines with nitrogen from body oils, urine, perspiration, etc. Chloramines can cause eye irritation as well as strong odors. Unlike bromamines, chloramines are very weak sanitizers.

**Chlorine:** An efficient sanitizing chemical for spas. Watkins Manufacturing Corporation recommends the use of "Sodium Dichlor" type granulated chlorine for sanitizing the water. This type is preferred as it is totally soluble and nearly pH neutral.

**Chlorine (or Bromine) Residual:** The amount of chlorine or bromine remaining after chlorine or bromine demand has been satisfied. This residual is, therefore, the amount of the sanitizer which is chemically available (FREE CHLORINE) to kill bacteria and algae.

**DPD:** The preferred reagent used in test kits to measure and indicate Free Available Chlorine.

**Halogen:** Any of the five elements; fluorine, chlorine, bromine, iodine and astatine.

**ORP:** Oxidation Reduction Potential; the combined value of oxidizers in spa water such as chlorine and ozone (measured in millivolts). The recommended ORP level of spa water is 650. Recommended testing method is with an electronic REDOX potential value tester.

**NOTE:** Even though ORP testing is the recognized method for commercial spas and pools and water treatment facilities, it is not practical for the homeowner because of the number of variables affecting the accuracy of the measurement device. A DPD test kit which measures a sanitizer's residual is always recommended.

**OTO:** A test reagent used to measure total chlorine in spa water. OTO can't distinguish between Free Available Chlorine and Combined Chlorine, so it is less desirable than DPD.

**Ozone:** Ozone is a powerful oxidizing agent and disinfectant which is produced in nature or artificially by man. Ozone forms no by-product such as chloramines (ozone actually oxidizes chloramines) and will not alter the spa water's pH.

**pH:** The measure of acidity and alkalinity. The recommended pH for spa water is 7.4 to 7.6. Below 7.0 (considered neutral), the spa water is acidic and can damage the heating system. Above 7.8 the water is too alkaline and can result in cloudy water and scale formation on the spa shell and heater.

**ppm:** An abbreviation for "parts per million," the accepted measurement of chemical concentration in spa water.

**Phenol Red:** A chemical reagent used in testing for pH.

**Reagent:** A chemical material in liquid, powder or tablet form for use in chemical testing.

**Scale:** Rough calcium bearing deposits that can coat spa surfaces, heaters or plumbing lines, and clog filters. Generally, scaling is caused by mineral content combined with high pH and enhanced by hot water.

**Super-chlorination:** Also known as "shock treatment." A super-chlorination is a process of adding significant doses of a quick dissolving sanitizer ("dichlor" is recommended) to oxidize non-filterable organic waste and to remove chloramines and bromamines.

**Total Alkalinity:** The amount of bicarbonates, carbonates, and hydroxides present in spa water. Proper total alkalinity is important for pH control. If the TA is too high, the pH is difficult to adjust; if it is too low, the pH will be difficult to hold at the proper level. The desired range of TA in spa water is 125 to 150 ppm.

## USE OF THE TEST KIT

The use of a test kit is absolutely essential for maintaining chemically balanced water. The test kit (a calibrated test block and reagents) allows you to test the water for chlorine levels, pH, and other measures such as total alkalinity. You should make these tests daily until user load is established, then several times weekly to be sure proper levels are maintained.

A few simple precautions must be taken to ensure maximum efficiency and accurate test data:

1. Water samples for each test should be taken at least 18" below the surface of the water. Rinse the test cells before and after each use. Do not dispose of test samples in the spa water.
2. Test comparisons should be made in natural light.
3. Reagents should be replaced at least yearly to maintain accuracy of test results.
4. When adding drops of reagents, the bottle must be held vertically and the drops added slowly to insure correct quantities are administered.
5. All test reagents should be kept out of the reach of children.

**CHLORINE TEST NOTE:** Because of its accuracy, a "DPD" test is recommended by Watkins Manufacturing Corporation when checking the "FREE CHLORINE" residual in your spa.

**MAINTAIN A CHLORINE TEST KIT  
READING OF 3.0 - 5.0 PPM OF FREE  
CHLORINE RESIDUAL.**

## Free Chlorine Test

1. Remove the stopper plug from the test block chamber marked either CHLORINE or CL.
2. With your finger tightly covering the CL chamber, dip the test block into the spa water. At a level approximately 18" below the water surface, remove your finger and allow the chamber to fill to the top line. Remove the test block from the spa water.
3. Place one **DPD #1** tablet in the filled CL chamber. Do not touch the tablet with your fingers as this may result in a false reading.
4. Replace the stopper plug on the test chamber and shake the test block vigorously to dissolve the tablet (15-30 seconds).
5. Make a comparative test of the color in the chamber to the color standards on the test block. This reading will be your Free Chlorine residual level.

**NOTE:** An alternative to the DPD test kit is the two-function OTO and Phenol Red Kit. The OTO test is slightly less reliable than the DPD test as it only measures the Total Available Chlorine Level (free chlorine residual **and** combined chlorine). If you super-chlorinate your spa water as recommended, the level of chloramines (combined chlorine) should not substantially affect the OTO chlorine test reading.

## HOT SPRING PORTABLE SPA STANDARD CHEMICAL SANITATION PROGRAM

CHLORINE DPD TEST KIT READING	DO NOT USE THE SPA UNTIL THE TEST KIT READING IS BELOW THIS LEVEL
5.0 —	<b>RECOMMENDED LEVEL SAFE</b>
4.0 —	
3.0 —	
<b>ADD CHLORINE</b>	
2.0 —	<b>DO NOT USE SPA; ADD CHLORINE TO REACH RECOMMENDED SAFE LEVEL</b>
1.0 —	
0 —	

## HOT SPRING PORTABLE SPA EQUIPPED WITH AN OZONE PURIFICATION SYSTEM

CHLORINE DPD TEST KIT READING	DO NOT USE THE SPA UNTIL THE TEST KIT READING IS BELOW THIS LEVEL
5.0 —	<b>SAFE</b>
4.0 —	
3.0 —	
2.0 —	<b>RECOMMENDED LEVEL WITH OZONE SYSTEM SAFE</b>
1.0 —	<b>DO NOT USE SPA; ADD CHLORINE TO REACH RECOMMENDED SAFE LEVEL</b>
0 —	

**pH Test:** The pH of the spa water should be tested with a Phenol Red reagent and compared to the calibrated color standards on the test block.

**THE RECOMMENDED pH FOR YOUR SPA WATER IS 7.4 - 7.6.**

**NOTE:** The spa water should be calm for at least an hour prior to testing for pH.

pH		
ALKALINE SPA WATER (SCALING ZONE)	8.2	ADD pH DECREASER TO LOWER pH
	7.8	
COMFORT ZONE		
	7.6	IDEAL
	7.4	
ACIDIC SPA WATER (CORROSIVE ZONE)	7.2	ADD pH INCREASER TO RAISE pH
	6.8	

**Total Alkalinity Test:** The total alkalinity content of your spa water should be maintained in the 125 to 150 ppm range. Your HOT SPRING SPA dealer can supply you with test strips or should be able to test the mineral content of the spa water for you.

### ADDING SPA WATER CHEMICALS

**IMPORTANT:** ALL SPA WATER CHEMICALS MUST ALWAYS BE ADDED DIRECTLY INTO THE FILTER COMPARTMENT WHILE THE HYDROTHERAPY JET PUMP IS OPERATING.

This includes granulated Dichlor, granulated pH Increase or Decrease, granulated Total Alkalinity Increaser, liquid Stain and Scale Inhibitor, liquid De-Foamer, and any other type of approved spa water chemical.

To Administer Spa Water Chemicals:

1. Fold back the thermal cover; carefully remove and set aside the filter compartment cover.
2. Push the button labelled "Timed Jets" to get the hydrotherapy jet pump operational.
3. Carefully measure the recommended amount of spa water chemical and slowly pour it into the filter compartment ( Refer to the Sanitation Table for dichlor amounts; follow the directions on the spa chemical container for recommended amounts.) Use care not to splash chemicals on your hands, in your eyes or on the spa shell surface.

4. Replace the filter compartment cover, close and secure the thermal cover. The hydrotherapy jet pump will automatically shut off after 10 minutes thus completing the application procedure.

**NOTE:** Prior to walking away from the operating spa, glance at the "Timed Jets" button and ensure the red indicator light is on.

**IMPORTANT:** "Super-chlorination/shock treatment"

**NOTE:** When administering a super-chlorination treatment to your spa water, it is advisable to open the thermal cover at least half way to allow the chlorine gas to vent off. This venting is extremely important on spas equipped with ROVEL Thermal Covers because of their almost perfect sealing capability. The high concentration of trapped chlorine gas which may exist as a result of super-chlorination (not daily sanitation) may eventually cause discoloration or vinyl degradation to the bottom of the thermal cover.

**Never leave an open spa unattended if children are present!**

**WARNING:** Do not turn off the jet pump prior to the end of the 10-minute "clean-up" cycle if chlorine has been administered to the spa water. If undissolved chlorine remains in the seating or foot well area, it may not only bleach out the color of the spa shell, but may result in paper thin chemical burns (blisters).

Chemical induced surface blistering is classified as abuse and is not covered under warranty. Additionally, there is no spa surface material (fiberglass, gelcoat or acrylic) that will withstand this type of abuse.

**IMPORTANT:** Granulated chlorine will degrade if stored improperly or for a long period of time. We recommend purchasing granulated Dichlor in one or two pound containers and storing it in a cool place to maintain the chlorine's freshness. Use care when handling.

**CAUTION/WARNING:** Watkins Manufacturing Corporation does not recommend the use of any type of floating chemical dispenser.

## SANITATION Chlorine

There are several forms of stabilized chlorine available for use in spas and swimming pools. Each form has specific chemical characteristics which makes it **EXTREMELY IMPORTANT** that you use the one specifically designed for small bodies of water such as spas.

**WARNING:** Using the **incorrect** product such as Trichlor, which has a very low pH (2.6), dissolves very slowly, is highly concentrated, and was designed for concrete or plaster swimming pools—will cause damage to your HOT SPRING SPA!

**Watkins Manufacturing Corporation recommends ONLY "Sodium Dichlor" type granulated chlorine be used for sanitizing the water.**

**Your HOT SPRING SPA water should not be BELOW A MINIMUM level of 2 ppm Free Available Chlorine Residual unless the spa is equipped with an Ozone Purification System. Then, a DPD test kit reading of 1 ppm–3 ppm Free Available Chlorine Residual is acceptable.**

To maintain the minimum level, Sodium Dichlor type granulated chlorine must be added to your spa **daily**. It is also advisable to check the free chlorine residual regularly, especially just prior to use. It is important to note that a spa being used over an extended

period of time, such as a whole afternoon or evening, will need chlorine added at least every hour or more frequently to maintain the **minimum** level of 2 ppm Free Chlorine Residual. The recommended **maximum** chlorine level when **using** your spa is 5 ppm or less.

In addition to maintaining your spa's Free Chlorine Residual in the 3 ppm—5 ppm range or 1 ppm—3 ppm range for a spa equipped with an ozone system, a **weekly** "shock treatment" is required. When using a chlorine water sanitation system, the shock treatment is a process in which you add substantial amounts (see Sanitation Table) of Sodium Dichlor to SUPER-CHLORINATE your spa water to a level of 10 ppm. This super-chlorination destroys chloramines and non-filterable organic wastes. After the super-chlorination, allow the chlorine level to drop below 5 ppm before using your spa.

**If you use your HOT SPRING SPA daily, the water should be SUPER-CHLORINATED to a level of 10 ppm at least once per week to oxidize chloramines and organic wastes.**

As a final note, super-chlorination is recommended after refilling your spa each time. This process will kill any bacteria which may be present in the plumbing or may have entered the spa during non-use.

**WARNING:** Improper chemical maintenance may increase the risk of catching or spreading infection. Also, no one should be in the spa while chemicals are being added or dissolving.

### SANITATION TABLE

SPA GALLONAGE	200-225 GAL	300-326 GAL	400-425 GAL	500-525 GAL
DAILY CHLORINATION	3/4 TSP	1 TSP	1 1/2 TSP	2 TSP
WEEKLY SUPER-CHLORINATION	2 TSP	3 TSP	4 TSP	5 TSP

**RECOMMENDED SANITIZER:** Sodium dichloro-s-triazinetriene, granular **or** Sodium dichloro-isocyanurate, granular (Common Name: Dichlor Chlorine, granular, 53%-65% available chlorine).

**DAILY CHLORINATION:** Maintain level of 3-5 ppm free available chlorine residual or 1-3 ppm residual for a spa equipped with an Ozone Purification System. Push in the button labelled "Timed Jets" and add the recommended amount of dichlor **into** the filter compartment while the jet pump is operating. The jet pump will shut off automatically after 10 minutes.

**NOTE:** A spa with an Ozone Purification System will require less chlorine than stated in the Sanitation Table to achieve the recommended 1-3 ppm chlorine residual.

**WEEKLY SUPER-CHLORINATION:** Push in the button labelled "Timed Jets" and add the recommended amount of dichlor **into** the filter compartment while the jet pump is operating to raise the free available chlorine residual **above 10 ppm**. The thermal cover should remain open during a "shock treatment." Once the jet pump has shut off after the 10 minute clean-up cycle, close and secure the thermal cover. Allow the free chlorine residual to drop to 5 ppm or below before using the spa!

## WATER PURIFICATION – OZONE GENERAL INFORMATION

The HOT SPRING Ozone Purification System is designed to greatly enhance the quality of the spa water when it is used to supplement the spa owner's regular water maintenance program. Contrary to some information circulated throughout the pool and spa industry regarding ozone systems, there is limited third party data available to support claims that ozone can be used as a single-source sanitizer, water clarifier, anti-foamer, and mineral chelating agent. Watkins Manufacturing Corporation recommends that a chemical maintenance program based on recognized and documented industry standards still be followed when using an ozone purification system to assure water sanitation and the highest quality purified water is achieved.

**The minimum recommended flow meter settings for HOT SPRING SPAS equipped with an Ozone Purification System are: GRANDEE, HIGHLIFE, CLASSIC (FH) and SOVEREIGN (IH)-2.5, CLASSIC (F), SOVEREIGN (I), PRODIGY and JETSETTER-1.5..**

### Questions and Answers regarding the HOT SPRING Ozone Purification System:

#### 1. What is ozone?

*Ozone is a powerful oxidizing agent which is produced in nature or artificially by man. In nature, ozone is produced in the lower atmosphere to purify the air we breathe. In the upper atmosphere, ozone is produced by the sun's U.V. light, forming a shield around the earth which filters out some of the sun's harmful rays.*

#### 2. How does ozone purify?

*The HOT SPRING Ozone Purification System produces ozone at your spa site to "burn out" water contaminants, bacteria and viruses through the process of oxidation.*

#### 3. What is the HOT SPRING Ozone Purification System?

*The purification system has been specifically designed to operate on all HOT SPRING SPAS manufactured with the 24-hour continuous filtration system (1989 and later models). The system utilizes a high output generator and an ozone resistant flow meter to regulate and monitor the amount of ozone delivered to the spa. To ensure that the ozone is transferred to the spa water efficiently, a special ozone injection system was designed based on the hydraulics of the spa's circulation system. The ozone generator is U.L. listed and the delivery system utilizes*

*double-insulated ozone resistant tubing and fittings and is protected by dual check valves.*

#### 4. How does the HOT SPRING Ozone Purification System work?

The HOT SPRING Ozone Purification System generates ozone from ambient air surrounding the unit using a special ultraviolet lamp. The frequency of light from this lamp converts the oxygen (O<sub>2</sub>) contained in the air to ozone (O<sub>3</sub>). As the water from the spa's circulation system flows through the ozone injector, ozone gas is drawn through the delivery tubing into the water flow as a result of venturi action. The ozone gas inside the extremely small bubbles is quickly absorbed into the water where it immediately begins oxidizing all contaminants, particularly, the spa water that is continuously circulating back into the spa through the heater return. Because of the efficiency of the ozone delivery system, a minimum of off-gassing occurs. (Off-gassing is identified as the amount of active ozone that reaches the spa water surface prior to its converting back to oxygen.)

#### 5. Why is ozone used for spa water treatment?

Ozone has five major benefits or advantages that make it ideal for water treatment:

1. Ozone is the most powerful oxidizing agent commercially available, out-performing chlorine and bromine. (But, ozone does not maintain a residual and as a result a sanitizer residual is required.)
2. Ozone is the most effective viral disinfectant commonly available for water treatment.
3. Ozone forms no harmful by-products such as chloramines.
4. Ozone will not alter the water's pH.
5. Ozone reduces the average chemical usage a minimum of 50%.

For additional information, please contact your authorized HOT SPRING SPA dealer.

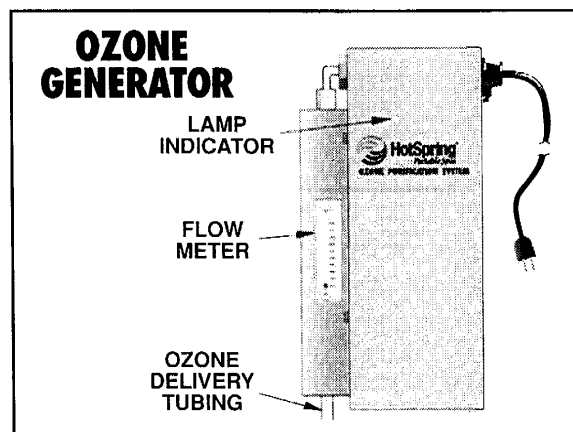

## **pH CONTROL**

Maintaining proper pH is extremely important for sanitizer effectiveness, user comfort, and for preventing equipment deterioration. pH is the measure of acidity and alkalinity in the water. The proper level is 7.4 to 7.6. This level is not only considered safe for spa surfaces and equipment, but is a comfortable level for a spa user's skin.

If a pH is high (above 7.8), chlorine sanitizers are less effective, spa surfaces and equipment can scale, water may become cloudy, and filter cartridge pores may become obstructed. Correct this high pH condition by adjusting with a pH "decrease" additive.

Low pH (below 7.0) causes sanitizers to dissipate more rapidly, increases corrosion of equipment, and may make the water irritating to spa users. Adjust low pH by using a pH "increase" additive.

**IMPORTANT:** Spa water additives for pH control should always be added into the filter compartment while the jets are running. Failure to maintain proper pH will result in damage to various components, including the ROVEL surface, and may void your warranty.

## **SUPPLEMENTAL WATER MAINTENANCE Mineral Content**

Proper mineral content is also an important factor in spa water. Total Alkalinity (TA) and Calcium Hardness (CH) are the primary minerals of concern. Total alkalinity is a measure of the buffering capacity of water, or its ability to resist a change in pH. Technically, total alkalinity is the total of carbonates, bicarbonates, hydroxides, and other alkaline substances in the water. When total alkalinity is too low, it will cause the pH level to fluctuate widely and can result in corrosive water. When total alkalinity is too high, the pH level will tend to be high (and difficult to lower) and may cause scale to form on the spa surface and equipment.

Low levels of calcium (water too soft) can lead to corrosion of equipment and staining of the spa shell surface. High levels of calcium can cause scaling of equipment and the spa shell surface.

Check with your HOT SPRING SPA dealer for recommendations on controlling these mineral related problems.

Proper water sanitation and mineral balance (pH control) are ABSOLUTELY essential for a spa water maintenance program. The following four points are optional:

### **Flocculating Agent**

A flocculating agent consists of relatively large particles which when added to water attract very small particles to them like a magnet. These small particles will normally go through some cartridge filters. When they are attached to the flocculent particles, however,

the combination is large enough to be trapped. The flocculent allows clarification of water contaminated with particles too small for some filters. Water sanitation is not improved by flocculating agents because with proper chlorination these small particles are rendered inert (biologically dead).

### **Water Color Control**

Water color in a shallow body of water such as a spa assumes the color of the spa. This can be seen in a swimming pool where the deep end seems to be tinted blue while the shallow end appears white. Some spa products have a blue appearance and will impart a blue color to the spa water.

### **Soap Foam Inhibitor**

The main reason water change is necessary in a hydrotherapy spa is soap build-up in the water. The soap comes from users' bodies, which retain soap residual after showering, and also from swimming apparel, which retains soap after washing. Foam inhibitors will suppress foam but cannot remove soap from water. The soap is not oxidized by any chemical (except by ozone). Eventually the soap build-up in the water will be concentrated enough to leave an unclean feeling on the skin and make the water impossible to clarify. Depending on the soap input, the spa water should last between two and three months.

### **Mineral Deposit Inhibitors**

As water evaporates from your spa, and make-up water is added, the amount of dissolved minerals that the spa water contains increases. The spa water will eventually become "hard" enough to damage the heater by calcifying the surface. Proper pH control can minimize this. Normal soap build-up demands water replacement regularly enough to where mineral depositing usually is not a problem. Keeping a lid on the spa will reduce evaporation substantially, and delay the water's hardening. Occasionally, high copper content or high iron content in the water may produce green or brown stains on the spa. In these cases, a mineral deposit inhibitor may be of help.

**SERVICE NOTE:** *Well water may contain high concentrations of minerals. The use of a low water volume, extra fine pore water filter will help to remove many of the larger particles during the filling of the spa. These in-line, prefilters can usually be purchased at a hardware or plumbing supply store.*

**IMPORTANT:** Contact your local HOT SPRING SPA dealer if you have a specific water chemistry problem or require assistance in developing a "spa care" program.



## SPA WATER MAINTENANCE Troubleshooting Guide

<b>PROBLEM</b>	<b>PROBABLE CAUSE</b>	<b>SOLUTIONS</b>
<b>Cloudy Water</b>	<ul style="list-style-type: none"> <li>• Inadequate filtration/dirty filter</li> <li>• Excessive oils/organic matter</li> <li>• Improper sanitation</li> <li>• High pH and/or high alkalinity</li> <li>• Suspended particles/organic matter</li> <li>• Overused or old water</li> </ul>	<ul style="list-style-type: none"> <li>• Clean filters with a filter cleaner or degreaser.</li> <li>• Shock the spa with chlorine (super-chlorinate).</li> <li>• Increase sanitizer to recommended level.</li> <li>• Adjust pH; add appropriate sodium bisulfate product.</li> <li>• Use clarifier.</li> <li>• Drain the spa, clean and refill.</li> </ul>
<b>Water Odor</b>	<ul style="list-style-type: none"> <li>• Excessive organics/ too many chloramines –insufficient free available chlorine</li> <li>• Improper sanitation</li> <li>• Low pH</li> </ul>	<ul style="list-style-type: none"> <li>• Shock the spa with chlorine.</li> <li>• Increase sanitizer level to recommended level.</li> <li>• Raise pH with sodium bicarbonate product.</li> </ul>
<b>Chlorine Odor</b>	<ul style="list-style-type: none"> <li>• Too many chloramines–insufficient free available chlorine</li> <li>• Low pH</li> </ul>	<ul style="list-style-type: none"> <li>• Shock the spa with chlorine.</li> <li>• Adjust pH; raise pH with sodium bicarbonate product.</li> </ul>
<b>Musty Odor</b>	<ul style="list-style-type: none"> <li>• Bacterial or algae growth</li> </ul>	<ul style="list-style-type: none"> <li>• Shock the spa with chlorine. If problem visible, draining and cleaning may be required.</li> </ul>
<b>Foaming</b>	<ul style="list-style-type: none"> <li>• Buildup of body oils, lotion and chemicals resulting in soap or detergent</li> <li>• Overused or old water</li> <li>• Excessive organics</li> </ul>	<ul style="list-style-type: none"> <li>• Add defoamer; or drain and refill.</li> <li>• Drain and refill.</li> <li>• Shock with chlorine.</li> </ul>
<b>Organic Buildup/Scum Ring Around The Tub</b>	<ul style="list-style-type: none"> <li>• Body oils and dirt</li> <li>• Inadequate filtration</li> </ul>	<ul style="list-style-type: none"> <li>• Wipe off scum with a clean rag. Depending on severity–drain spa, use a spa surface and tile cleaner to remove the scum, refill spa and adjust water.</li> <li>• Clean filter with a filter cleaner or degreaser.</li> </ul>
<b>Algae</b>	<ul style="list-style-type: none"> <li>• High pH</li> <li>• Low free chlorine</li> </ul>	<ul style="list-style-type: none"> <li>• Shock with chlorine; adjust pH.</li> <li>• Shock with chlorine; maintain sanitizer at recommended level.</li> </ul>
<b>Eye Irritation</b>	<ul style="list-style-type: none"> <li>• Low pH</li> <li>• Insufficient free available chlorine</li> </ul>	<ul style="list-style-type: none"> <li>• Raise pH with sodium bicarbonate product.</li> <li>• Shock with chlorine.</li> </ul>
<b>Skin Irritation/Rash</b>	<ul style="list-style-type: none"> <li>• Unsanitary/polluted water</li> </ul>	<ul style="list-style-type: none"> <li>• Maintain recommended sanitizer residual at all times; super-chlorinate.</li> <li>• Chlorine level too high (above 5ppm FAC).</li> </ul>
<b>Stains</b>	<ul style="list-style-type: none"> <li>• pH or total alkalinity too low</li> <li>• High iron or copper in water source</li> </ul>	<ul style="list-style-type: none"> <li>• Adjust pH and total alkalinity; use sequestering agent; drain and clean with appropriate product.</li> <li>• Use sequestering agent for metals; adjust water.</li> </ul>
<b>Scale</b>	<ul style="list-style-type: none"> <li>• Too much calcium dissolved in water–pH and total alkalinity too high</li> </ul>	<ul style="list-style-type: none"> <li>• Adjust total alkalinity and pH levels by adding the appropriate sodium bisulfate product; with concentrated scale deposits–drain the spa, scrub the scale off, refill the spa and balance the water.</li> </ul>

## CHEMICAL SAFETY AND STORAGE

When using chemicals, read labels carefully and follow directions precisely. Though chemicals protect you and your spa when used correctly, they may be hazardous in a concentrated form. Observe these guidelines:

1. Accurately measure and use the exact quantities specified, never more. Do not overdose.
2. Handle all containers with care. Store in a cool, dry, well ventilated place.
3. Always keep chemical containers closed when not in use. Replace caps on proper containers.
4. Allow only a responsible person to handle spa chemicals. Keep them out of the reach of children.
5. Don't inhale fumes or let chemicals come in contact with your eyes, nose or mouth. Wash your hands after use.
6. Follow the emergency advice on the product label in case of accidental contact, or if the chemical is swallowed. Call a doctor or local Poison Control Center. If a doctor is needed, take the product container along so that the substance can be identified.
7. Don't let chemicals get on surrounding surfaces or landscaping. Don't use a vacuum cleaner to clean up chemical spills.
8. Don't smoke around chemicals. Some fumes can be highly flammable.

## DO'S AND DON'TS OF SPA WATER MAINTENANCE

1. Many sanitizers, though of the same chemical family, have differing rates of solubility and pH. Their effectiveness could either be substandard or exceptionally harsh and damaging to the spa surface and equipment. For this reason:  
**DO NOT** use "Tri-Chloro" granulated or tablet chlorine.  
**DO** use Sodium Dichlor type granulated chlorine.
2. Your HOT SPRING SPA dealer may recommend a BROMINE spa water sanitation program. Whereas bromine and bromamines (the combined form of bromine) are effective sanitizers, the methods in which it is administered to the spa water and the quality and composition of the product varies from each chemical manufacturer. The use of bromine sticks or tablets in floaters which may become

entrapped on a lounge or cooling seat (or sink to the spa floor) have shown to cause discoloration or surface distress to the PVC and ABS spa fittings. (The ROVEL spa shell can withstand the effects of Bromine except in instances where a floating dispenser becomes entrapped or if the dispenser is set on too high of a setting, thus creating an "over-bromination" or "high concentration" situation. In these situations, discoloration to the spa shell may occur.) In addition, automatic floating dispensers either have a tendency to "over" brominate or "under" brominate as the rate of erosion varies greatly and must be monitored. For these reasons, we strongly recommend:

**DO NOT** use a bromine sanitation system as a low or no maintenance solution to your spa water sanitation program. If a bromine sanitation system is used, Quick-Dissolving Granulated Bromine is recommended. If a bromine sanitation system utilizing a floating dispenser is used (this method is not recommended by Watkins Manufacturing), carefully follow your authorized dealer's written instructions and discontinue its use immediately should signs of discoloration to the spa shell surface occur.

3. Many sanitizers may raise the level of total dissolved solids in water or are dangerous to handle. For this reason:  
**DO NOT** use household bleach (liquid sodium hypochlorite).
4. Many swimming pool water care products can cause damage to spa surfaces and equipment of smaller bodies of water such as spas. For this reason:

**DO NOT** use swimming pool (muriatic) acid to lower pH.

5. Many pH "increase" additives in the carbonate chemical family will cause redwood to turn dark by pulling the tannin (reddish color in redwood) out of the wood. For this reason:

**DO NOT** splash pH "increase" additives on the redwood skirt during pH adjustment.

**DO** use care if using baking soda to clean either the interior or the exterior plastic spa surfaces.

6. The instructions for use on many spa product labels recommend casting or sprinkling the chemicals onto the water surface. This method may cause chemically induced spa surface blistering (chemical abuse). For this reason:

**DO NOT** add chemicals directly onto the water surface.

**DO** add all chemicals slowly into the filter compartment.

## VII. SERVICE INFORMATION

### GENERAL INFORMATION

The HOT SPRING SPA has been designed to provide years of trouble-free use. As with any appliance, problems may occasionally occur that require the expertise of a qualified service person. Though such simple repairs as resetting a G.F.C.I. switch or breaker, resetting a high limit thermostat or replacing a light bulb may not require a service call, they may indicate a more serious condition exists. These conditions may require an experienced service person. Before calling for service, please refer to the TROUBLESHOOTING GUIDE.

**SERVICE NOTE:** *If the SOVEREIGN has a ROVEL spa cover, it may be necessary to "tap out" and remove the hinge pins from the equipment compartment door hinges prior to servicing of the spa components. By doing so, the door can be completely removed and allow for unobstructed access to the equipment compartment.*

**NOTE:** Always retain your original sales receipt for future reference.

### G.F.C.I. AND HIGH LIMIT THERMOSTATS

If your spa fails to operate at any time, the following items should be checked in this order:

1. Check the G.F.C.I. and see if it has tripped. (On 220 Volt models, check each of the G.F.C.I. breakers in the sub-panel.) If a G.F.C.I. has tripped, reset it. If it will not reset, this may be an indication of a ground fault (short circuit) within the electrical components. Contact an authorized service technician for a complete diagnosis.
2. If upon checking the G.F.C.I.'s you find that they have not tripped, check the house breaker panel and ensure the main breaker for the electrical circuit supplying the spa has not tripped. If it has, this is an indication that the circuit was either overloaded or a ground fault exists between the breaker panel and the spa receptacle or sub-panel. Contact a qualified electrician.
3. If upon checking the main house breaker and spa G.F.C.I.'s you find no failures, check to see that the equipment compartment door on the spa has been secured completely.
4. If upon checking the above listed items you find everything in order, the high limit thermostats should be checked. Their functions are described as:

### Heater High Limit Thermostat

The heater high limit thermostat sensor is located in a dry well within the heater housing. If for any reason the internal temperature of the heater exceeds 150 degrees F, the red "RESET" button on this switch will trip and turn off the spa. This switch is described as "trip free"; that is, it cannot be reset or the circuit closed by physically holding in the button, until the sensor bulb cools to approximately 115 degrees F. The cause of the tripping must be located to prevent a recurrence. The reason for tripping is usually a result of inadequate water flow through the heating system. This is caused by clogged filter cartridges, a non-functioning heating system, circulation pump, or an obstruction at the heater return.

### Spa High Limit Thermostat

The spa high limit thermostat sensor is located behind the control thermostat sensor in the heater system dry well. Its purpose is to shut off all power to the spa should the control thermostat or heater relay stick close, or should the jet pump be left running with the thermal cover in place for an extremely long period of time. In either case, as the water temperature approaches 118 degrees F, this switch will trip. It must be reset manually after the cause is determined.

To check the Spa high limit and heater high limit thermostats, unplug the spa (or trip the G.F.C.I. breakers) and remove the screws which secure the equipment access door. Depress the red buttons labelled "HEATER RESET" and "RESET" which are located on the side of the control box. If either has tripped you will hear a click when the switch resets.

**NOTE:** The spa water temperature must be below 100 degrees F to reset the thermostat.

Be sure to close the equipment access door before restoring power to the spa. If the spa does not function, and the G.F.C.I.(s) and both high limits did not trip, refer the problem to a qualified service technician.

### OZONE PURIFICATION SYSTEM

The HOT SPRING Ozone Purification System is a low-maintenance electrical device. A blue glow from the lamp indicator located on the front face of the ozone generator will indicate the U.V. lamp is functional. Movement in the flow meter as well as the appearance of bubbles entering the spa water indicates air flow through the system. If the blue lamp indicator is illuminated and there is movement in the flow meter (within the recommended rate of flow) and ozone bubbles are entering the spa, then the system is operating correctly. If the blue indicator **is not** illuminated then either A) the U.V. lamp is burned out, or B) the lamp ballast is non-functional as a result of equipment failure or low temperature. (The ballast has a temperature rating of 5 degrees F. If

power was disconnected to the system when the ambient temperature was below 5 degrees F, then no malfunction exists. The system will operate once the ambient temperature has risen above 5 degrees F).

**WARNING:** The ultraviolet light produced by the ozone generator is hazardous to your vision. DO NOT operate the unit with the lamp cover removed. Watkins Manufacturing recommends servicing only by a trained HOT SPRING SPA technician.

All HOT SPRING SPAS are equipped with a 24-hour continuous filtration system. Because the Ozone Purification System injector is connected in-line with the filtration/heater circulation system, the ozone generator system will run continuously. As a result, the flow of warm ozone air will prevent condensation from freezing in the ozone delivery tubing even in the severest of weather conditions. If freezing of the delivery tubing does occur (as indicated by no flow through the meter, but a blue glow is noticeable at the lamp indicator), then ice blockage of the delivery tubing may have occurred. If freezing has occurred, it is a result of A) the ozone flow was not sufficient to prevent freezing in which case the rate of flow should be increased (or the spa's filter cartridges should be cleaned to increase the water circulation rate and venturi action on the ozone delivery tubing), or B) water has backed up into the delivery tubing as a result of a check valve failure.

Your authorized HOT SPRING SPA dealer should be contacted in the event component replacement or system evaluation is required.

## MISCELLANEOUS SERVICE INFORMATION

The control and high limit thermostat capillaries are not electrical wires. They are copper tubes with tiny bores which carry expansive fluid. NEVER cut, bend or kink them.

The jet pump is equipped with a thermal overload cutoff switch which is designed to protect the pump from overheating. If the pump shuts itself off in an older spa, it could indicate failure of the pump motor bearings. If the pump shuts itself off in a new spa, it is usually the result of one, or a combination of the following factors:

**Thermal Overload:** Although mass-produced, not all thermal overload cutoffs are exactly the same. Some are more sensitive than others and will shut the pump off at lower temperatures.

**High Temperature:** During the summer months, especially in warmer climates, the ambient temperature contributes to excessively high temperatures within the equipment compartment.

**Friction:** Sometimes the moving parts of a new pump are tight enough to cause heat build-up due to friction. After a normal break-in period, the pump will run cooler.

**Improper Wiring :** If the spa is connected to an extension cord, and/or the house wiring is undersized, the pump may starve for voltage and therefore draw more amperage and generate excessive heat.

If the pump is shutting down due to excessive heat, make sure the equipment compartment has adequate ventilation. The air gap at the bottom must not be blocked. Should your jet pump continue to shut off after short periods of use, contact a qualified service technician.

---

## ACTS INVALIDATING WARRANTY

The warranty is void if the HOT SPRING SPA has been subjected to alteration, misuse or abuse, or if any repairs on the spa are attempted by anyone other than an authorized representative of Watkins Manufacturing Corporation. Alteration is defined as any component or plumbing change, electrical conversion, or the addition of any non-approved sanitation or water purification device or heating system which contributes to a component failure, unit failure or unsafe operating condition. Misuse and abuse shall include, any operation of the spa other than in accordance with Watkins Manufacturing Corporation printed instructions or use of the spa in an application for which it is not designed. Specifically: use of the spa in a non-residential application, damage caused by operation of the spa at water temperatures outside the range of 32 degrees F and 120 degrees F, damage caused by dirty, clogged or calcified filter cartridges; damage to the spa surface caused by the use of Tri-Chloro chlorine, chemical tablets, acid, or any other harsh chemicals which are not recommended by Watkins Manufacturing Corporation; damage caused by allowing undissolved spa sanitizing chemicals to lie on the spa surface (no spa surface material can withstand this kind of abuse); damage to components or spa surface caused by improper pH balance or other improper water chemistry maintenance; and damage to the spa surface caused by leaving the spa uncovered while empty of water and in direct exposure to sunlight (this may cause solar heating distress in desert or hot weather regions) are considered abuses and may invalidate this warranty.

---

## DISCLAIMERS

Watkins Manufacturing Corporation shall not be liable for loss of use of the HOT SPRING SPA or other incidental or consequential costs, expenses or damages, which may include but are not limited to, the removal of a permanent deck or other custom fixture. Any implied warranty shall have a duration equal to the duration of the applicable warranty stated above. Under no circumstances shall Watkins Manufacturing Corporation or any of its representatives be held liable for injury to any person or damage to any property, however arising.

## TROUBLESHOOTING GUIDE

SYMPTOM	PROBABLE CAUSES	SOLUTIONS
<p>Entire spa Inoperative</p>	<ul style="list-style-type: none"> <li>• Power failure outside of spa.</li> <li>• G.F.C.I. tripped.</li> <li>• Equipment access door not completely closed.</li> <li>• HEATER high limit thermostat tripped.</li> <li>• SPA high limit thermostat tripped.</li> </ul>	<ul style="list-style-type: none"> <li>• Check power source.</li> <li>• Reset G.F.C.I.; call for service if will not reset.</li> <li>• Screw door closed.</li> <li>• Check for clogged filter cartridges (clean if necessary). Reset thermostat, call for service if it happens frequently.</li> <li>• Reset. If jets were left running with thermal cover on spa, spa was heated by water friction.</li> </ul>
<p>Jets weak or surging.</p>	<ul style="list-style-type: none"> <li>• Spa water level too low.</li> <li>• Dirty or clogged filter cartridges.</li> <li>• Air control valves closed or restricted.</li> </ul>	<ul style="list-style-type: none"> <li>• Add water.</li> <li>• Clean or replace filter cartridges.</li> <li>• Open air control valve.</li> </ul>
<p>Light inoperative.</p>	<ul style="list-style-type: none"> <li>• Burned out bulb.</li> </ul>	<ul style="list-style-type: none"> <li>• Replace bulb.</li> </ul>
<p>MOTO-MASSAGE JET inoperative or erratic.</p>	<ul style="list-style-type: none"> <li>• Air control valve closed or restricted.</li> <li>• Filters clogged or restricted.</li> <li>• MOTO-MASSAGE JET nozzle air line has pulled away from fitting.</li> </ul>	<ul style="list-style-type: none"> <li>• Open air control valve.</li> <li>• Clean or replace filter cartridges.</li> <li>• Remove face plate of MOTO-MASSAGE JET and push on air line. Refer to instructions, page 23.</li> </ul>
<p>"Timed Jets" Timer is inoperative.</p>	<ul style="list-style-type: none"> <li>• (On GRANDEE Model) Timed Jets Override Switch is turned OFF.</li> </ul>	<ul style="list-style-type: none"> <li>• Turn Timed Jets Override Switch to ON position.</li> </ul>

**IMPORTANT:** Refer to the spa and equipment drawings in the Spa Specification Section to locate the component or control identified in this Troubleshooting Guide.

# SPA CARE AND MAINTENANCE RECORD

## FICHE D'ENTRETIEN ET DE SOIN DU SPA

DATE	DRAIN & CLEAN SPA SHELL VIDANGE ET NETTOYAGE DE LA COQUILLE DU SPA	SPRAY CLEAN FILTER CARTRIDGE ARROSAGE DU CARTOUCHE DU FILTRE	SOAK FILTER CARTRIDGE TREMPAGE DU CARTOUCHE DU FILTRE	RESEAL/OIL REDWOOD SPA SKIRT RECELLAGE, HUILAGE DE LA JUPE DU SPA EN SECOUA	CLEAN & CONDITION VINYL SPA COVER NETTOYAGE & CONDITIONNEMENT DE LA COUVERTURE DU SPA EN VINYLE	WINTERIZE SPA ENTRETIEN D'HIVER DU SPA	MISCELLANEOUS SERVICE DIVERS





WATKINS MANUFACTURING CORPORATION  
VISTA, CALIFORNIA  
U.S.A.

This manual contains installation, operating, maintenance, and service information for the following HOT SPRING SPA models:

<u>U.S.A. Models</u>	<u>Effective Date</u>	<u>Canadian Models</u>	<u>Effective Date</u>
GRANDEE® (Model G)	— 1/91	GRANDEE® (Model GC)	— 3/91
HIGHLIFE® (Model K)	— 3/91	HIGHLIFE® (Model KC)	— 3/91
CLASSIC™ (Model F & FH)	— 1/91	CLASSIC™ (Model FHC)	— 3/91
SOVEREIGN® (Model I & IH)	— 1/91	SOVEREIGN® (Model IHC)	— 3/91
PRODIGY® (Model H)	— 1/91	PRODIGY® (Model HC)	— 3/91
JETSETTER® (Model J)	— 1/91	JETSETTER® (Model JC)	— 3/91